

# National Torches

## Made in USA

### Operating Procedures and Safety Information for Model 3H

#### Introduction

National torches are precision manufactured, field proven, and time tested for unsurpassed performance and reliability. Before operating any fuel gas and air or oxygen equipment read and follow the information in this instruction sheet or other qualified operation/training instructions. Torches using any combination of fuel gas and air or oxygen produce a high temperature flame that can result in property damage or severe personal injury if not used properly. Exercise caution when using this equipment.

The **National Model 3H** Hydrogen Hand Torch is specially designed for use with Hydrogen and Oxygen. The **3H** comes with an 8" stainless steel elbow and has 3/8-24, "A" size, threaded welding hose connections. A specially designed leak-proof "O" ring union permits the tip and elbow assembly to be rotated to any desired angle without the aid of a wrench. Now the flame can be easily directed to allow the most comfortable torch/hand position.

The **National Model 3H** oxygen / hydrogen torch is used with a variety of special tips to polish edges or through holes in acrylic or similar materials. The hydrogen and oxygen flame will not introduce contaminants into the material and the range of tips will allow you to polish stacked or solid materials up to 6 inches in width.

Do not alter or attempt to repair any fuel gas and air or oxygen equipment. Only factory trained repair personnel should perform repairs.

#### General Safety Information

- ♦ Protect your eyes at all times with approved goggles. Oxygen-fuel heating and brazing may produce hazardous rays (infrared/ultra-violet), so an approved filter lens (at least a number five shade or darker) should be used. Do not allow bystanders to look directly at your work without proper eye protection.
- ♦ Appropriate protective clothing such as gloves, aprons, safety shoes, etc. is required when using fuel-oxygen equipment. Reflected heat, molten metal or sparks can cause severe burns to unprotected parts of the body.
- ♦ Fuel gas and oxygen heating or brazing operations should be performed whenever possible in an open, well ventilated area. Combustion fumes and fumes from material or heated flux must be adequately exhausted or dispersed from the work area.

Use only compressed gas cylinders that are approved by the Department of Transportation (DOT), and follow the instructions and safety procedures provided by your gas cylinder supplier, such as:

- Cylinders must be in the vertical position when in use and secured from falling.
- Keep cylinder valve protection caps on and valves closed whenever cylinders are not in use.
- Locate cylinders away from flames or sparks.
- ♦ Never use compressed gases from cylinders without an approved gas pressure regulator attached to the outlet of the cylinder.
- ♦ Use caution to keep flames and heated objects away from the gas hoses.
- ♦ Use only a spark/friction lighter or approved pilot light to ignite the flame at the torch tip. Never use a match or cigarette lighter.
- ♦ It is recommended that flash arrestors be installed in the system between the regulator and the torch. Consult your gas cylinder or regulator supplier or local regulatory agency for installation and maintenance.

## **Installation**

National torches are connected to fuel and air or oxygen supplies with an industrial welding grade hose. Industrial welding grade hoses are generally color coded red for fuel gas, and green for oxygen. Supply ends of the hoses must have properly crimped screw fittings. Connect hoses to properly selected regulators and flash arrestors. Before attaching hoses to the torch, purge hoses individually to remove any preservative talc or cut-off particles by opening valves or regulators for 5 seconds when set at 5 psi pressure with hoses attached. The Model 3H torch uses "A" size (3/8-24) threaded hose connections, are also indexed right hand and left hand for air/oxygen and fuel, respectively. Simply make the threaded connections to an industrial welding grade hose set that is assembled with crimped ferrules for a leak free hook-up. If you do not have the facilities for applying hoses properly, consult your dealer or cylinder supplier who will provide proper fittings and attach them in most cases. Before lighting torch, test all connections with a dilute solution of soap and water. Never test with or near an open flame. Attach a hose to the threaded end of the relief valve on the hydrogen regulator and vent hose to the outside as required by OSHA.

## **Lighting and flame adjusting**

To light the 3H torch open the hydrogen valve only and light with an approved lighter. Once lit, add oxygen. Continue to add hydrogen then oxygen alternately until the individual hole flames just raise from the tip. Then reduce the gases slightly. This will prevent the tip from overheating. If the tip overheats, change to a smaller size tip. An overheated tip indicates an insufficient supply of fuel and oxygen. A hydrogen/oxygen flame is nearly invisible since there is no carbon in hydrogen. Viewing the flame against a black background or with reduced lighting greatly improves the visibility of the flame.

Shutting down the torch, close the oxygen valve first, then close the fuel valve. Always close cylinder valves when torch set-up will be left unattended.

## **Warranty**

Abbeon Cal Inc. (Abbeon) warrants to the initial user of products sold by Abbeon that such products are free from defects in material and workmanship, under normal use and service, for a period of ninety days from the date of installation or one year from the date of shipment from the factory, whichever comes first. Within this warranty period, Abbeon agrees to replace or repair at the factory any product found by Abbeon to have been defective in material or workmanship at no charge to the user. Abbeon will not pay for or warrant repairs made by anyone other than factory personnel.

Abbeon shall not be liable for consequential or indirect damages to the extent permitted by law. This warranty shall be the exclusive warranty and shall be in lieu of all implied warranties including implied warranties of fitness for a particular purpose or application. This warranty shall not apply to product that has been altered or modified except by Abbeon personnel or product that has been damaged by accident, abuse or misuse.

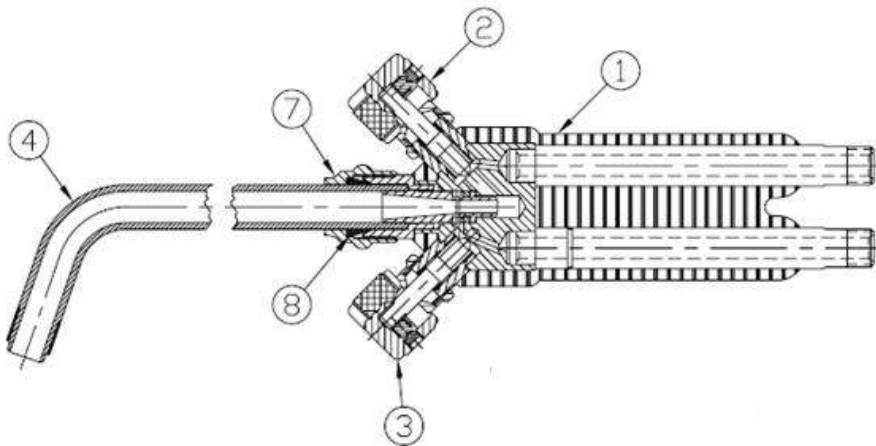

### **3H Torch Replacement Parts**

Item Description

- 1 Molded Body (not sold separately)
- 2 Green Valve Wheel and/or Valve Stem Assembly, Green
- 3 Red Valve Wheel and/or Valve Stem Assembly, Red
- 4 Elbow Assembly (Varies in length)
- 7 Elbow Nut
- 8 O-Ring and Gasket

CONSULT DISTRIBUTOR FOR REPLACEMENT PARTS FOR OTHER PRODUCTS

**Abbeon Cal, Inc.**, 1363 Donlon Street Unit 1, Ventura, CA 93003-8387  
800-922-0977 [www.abbeon.com](http://www.abbeon.com). E-mail: [abbeoncal@abbeon.com](mailto:abbeoncal@abbeon.com)