

HSK Kunststoff Schweißtechnik GmbH
HSK plastic welding technology GmbH



BEDIENUNGS- UND WARTUNGSANLEITUNG
FÜR HANDSCHWEISSEXTRUDER
SERIE HSK10 DE

Index:

	Page
1. General information	3
2. Technical Data	4
3. Explanation of symbols	4
4. Determination of use	4
4.1 Start-up	5
4.2 Handling of manual welding extruder	6
5. Operating instructions for regulator Omron E5GN	7
5.1 Mounting of regulator	7
5.2 Setting of set-point temperature	8
5.3 Setting of air temperature	8
6. Welding	8
7. Cutting off of manual welding extruder	8
8. Maintenance	9
8.1 Cleaning	9
8.2 Maintenance works	9
8.3 Change of die	10
8.4 Change of extruder screw	11
8.5 Change of welding nozzle	11
9. Defects and their possible reason	12
10. Spare parts list extruder	13
11. Wiring diagram	16
12. Air heater	18
13. Special accessories	19
14. Declaration of conformity	20

1. General information

Copyright holder of this documentation is HSK Kunststoff Schweißtechnik GmbH, Siegburg. It contains descriptions, technical drawings and enclosures which may not, neither partly nor entirely, be copied, distributed, used for competitive reasons or given to third parties without their permission.

These instructions have to be studied thoroughly prior to the start-up of the machine, as the manufacturer will not accept any liability for damage to persons and/or machine parts resulting from handling not in line with these directions.

These operating instructions are made for the practical use and should therefore be accessible to the operator at any time.

Please make sure that prior to repair and maintenance work at the welding extruder, the device must absolutely be disconnected from the electrical network.

On ordering spare parts the following specifications must be procured:

1. Machine-no.
2. Device (Extruder, drive or air heater)
3. No. of item corresponding to the spare parts list (see p. 15)

All necessary settings and, if necessary, adjustments to be carried out by skilled workers are described in the present operation manual. Should there, in spite of this fact, occur problems during start-up, we would ask you not to carry out unauthorized manipulations to the machine. You will endanger your health and risk to loose warranty. In this case please contact the nearest sales agency or get in direct contact with HSK KUNSTSTOFF SCHWEIßTECHNIK GMBH (see page 21).

2. Technical data

Voltage:	230 V / 50 Hz
Air heating:	1550 W
Cylinder heating:	300 W
Extruder drive:	500 W
Ø Wire:	4 mm

3. Explanation of symbols

Information of special importance in the present operating instructions is marked with the following symbols:

Information regarding security:



Information regarding maintenance:



4. Determination of use

The HSK manual welding extruders are suitable for the processing of the following plastic types:

LDPE, HDPE, LLDPE, PP, PVDF.

Excluded are filled or reinforced plastic types and principally all plastics having a melt index of MFI $190/5 < 0,5 \text{ g}/10 \text{ min}$.

The processing of materials not complying with above specifications is not tolerated as there is the danger of damaging the machine.

In special cases this specification can be extended after having contacted the manufacturer or his authorized agents.

On putting the heated or switched-on machine aside, the corresponding stand which is delivered with the machine has to be used. Please see to it that the machine has got a solid rest and the stand a safe position.

If the manual welding extruder is stocked in heated or switched-on condition, special care has to be taken to avoid any contact with easily inflammable or explosive products.



4.1 General procedure description

The extrusion welding (see Abb.1) is a manual or partial-mechanised weld procedure. One works with weld addition from wire (supply see Abb.2) or from granulate material which becomes in a plastification system (extrusion) melted. About a welding shoe formed according to the seam geometry the weld addition is pressed in the weld joint plastic as a rule by hot air of the basic material. The mass output achievement of the machines or devices determines the maximum weld dimension and influences the weld speed. The mass output achievement of the extrusion can be also regulated about the potentiometer (Nr.37). The necessary pressure is generated by the outcoming mass and the opposing force of the welder.



Abb.1



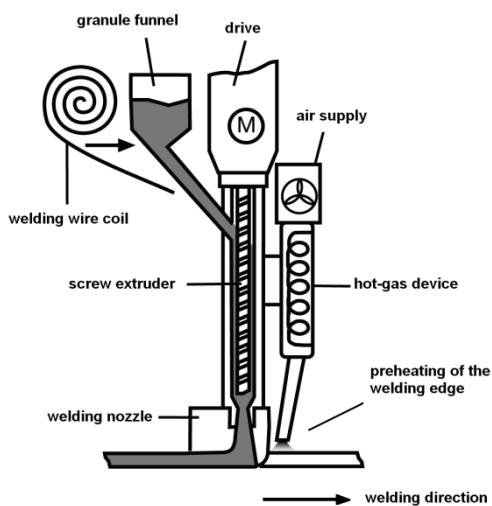

Abb.2

4.1.1 Start-up

Prior to the start-up of the machine it must be secured that the motor is cut off. If not, the on-off switch of the drive must be unlocked.

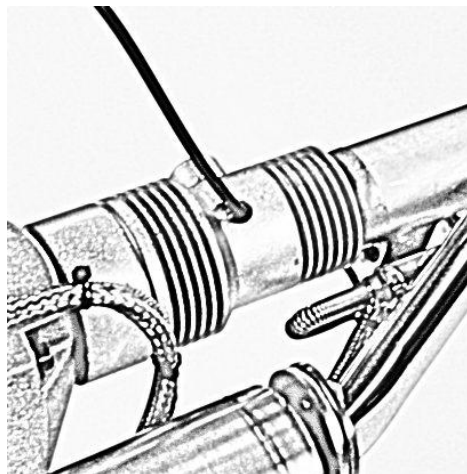
Prior to heating up the manual welding extruder the handle this is delivered with the machine, has to be mounted onto the cylinder.

After having procured the mains supply by connecting the plug, the heating of the manual welding extruder is switched on automatically.

By this action there is the danger of injury by burning at the places marked with a  in the following picture:

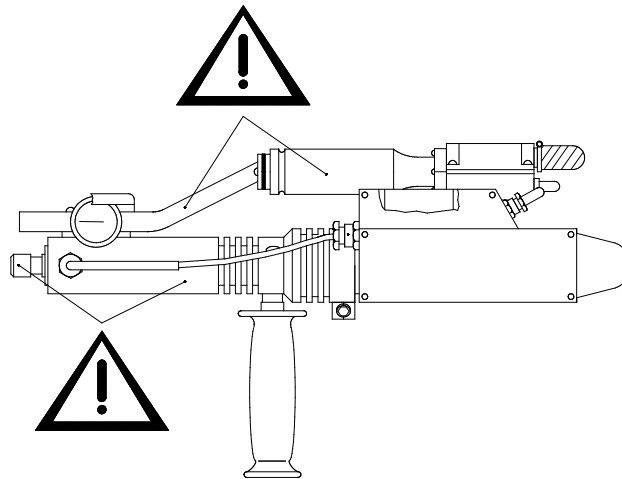

Please see to it that in air pre-heating nozzle materials which are easy inflammable or explosive.

front of the  there are no

Make sure that the set mass temperature (setting process see chapter 5.2) is suitable for the material to be welded.

With HSK manual welding extruders equipped with electronic regulation of the mass temperature, a minimum temperature of 180°C cannot be under run.

In special cases this figure can be changed after having contacted the manufacturer or his authorized agents.

Prior to the feeding of the welding wire the drive has to be switched on.

The welding wire has to be fed with slight pressure. Once the machine has seized the welding wire, the further intake is done automatically.

4.2 Handling of manual welding extruder

First operation of the machine has to be done as per chapter 4.1. The manual welding extruder may only be guided at the handles fixed to this purpose.

In order to avoid injuries by burning in case of improper handling, the operator has to wear heat-resisting gloves.

Further on all limbs of the operation staffs have to be covered by appropriate clothes.

If works have to be carried out over head or in narrow places (for ex. gully holes or narrow receptacles), a second person has to be present as a matter of security.



Please note that a welding with satisfactory results requires a faultless welding wire, a proper pre-heating and a perfect preparation of the welding.

Please make sure that the welding wire to be used is not too old and was stocked properly.

You will obtain best welding results by using dry and dust free air.

The preparation of the welding will depend on the materials to be welded and the welding geometry. For any information on the preparation of the welding please refer to existing literature or to the corresponding directives in the branch.

Existing regulations which have been established for many branches (for ex. DVS regulations) regarding the manufacture of plastic connections by welding have to be strictly observed.

5. Operating instructions for regulator Omron E5GN

DISPOSITION OF REGULATOR FRONT PLATE:

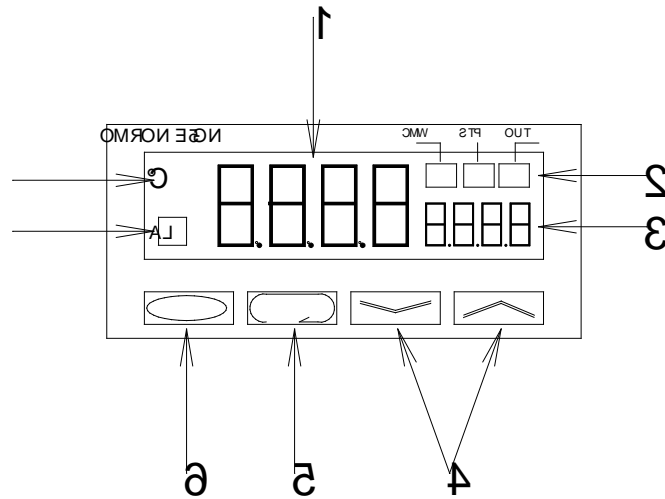

- 1) Display No. 1, shows actual value
- 2) Operation indicators
CMW, STP, OUT
- 3) Display Nr. 2, shows rated value
- 4) Up and down keys.
Use the keys to vary the setting for the rated value. Each press on the „up“-key increments or advances the values or settings. Each press on the „down“-key decrements or returns the values or settings
- 5) Changes the contents of the display
- 6) Used to change levels.
- 7) Alarm / operation function
- 8) Temperature unit

Never press keys 5 and 6 at the same time

For further information please refer to the regulators instruction manual.

5.1 Mounting of regulator

At first please disconnect the manual welding extruder from the electrical network!



The regulator has to be inserted into the switchboard cut-out from the front. Put the fastening frame from the rear and press it against the rear side of the switchboard. Afterwards insert the connector block into the regulator.

For taking the regulator out, first open the switch box.

Thereafter remove the contact strip. After removal of the fastening frame the regulator can be taken out of the switch box.

5.2 Setting of set-point temperature

The regulator is pre-adjusted at a set-point temperature of 220°C (mass temperature). This must be adapted by the operator to the material to be welded.

For the setting of the set-point temperature please proceed as follows:

The desired set-point temperature is shown in Display No. 2 (pos. 3) of the regulator.

By actuating the “up-key” the set-point temperature is raised.

By actuating the “down key” the set-point temperature is reduced.

Never press the “display” and the “level” key at the same time.

By doing this, you will enter into a level of the regulator which can solely be modified by the servicing personnel.

By re-actuating the „display“and the „level“key you can return to the start position of the regulator

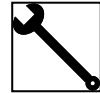

5.3 Setting of air temperature

The air temperature can only be adjusted with the air heater itself.

For information please refer to the air heaters instruction manual.

6. Welding

After set mass and air temperatures are reached the welding process can be started.

The temperatures to be applied will depend on the material to be welded and can be taken from the directions of the material’s supplier.

The following standard processing temperatures have been taken out of the DVS directions 2207, part 4:

Material	Mass temperature (°C)	Air temperature (°C)	Air quantity (l/min)
HD-PE	200 – 230	250 – 300	≥ 300
PP	200 – 230	250 – 300	≥ 300

7. Cutting off of manual welding extruder

After completion of the welding procedure, always empty the extruder by keeping it running without welding wire until there is no more material coming out of the die.

Thereafter you cut off the air heating with the switch (item no. 21). As soon as the air temperature is less than 100°C the air supply can be cut off.

After this the extruder can be cut off by pulling out the mains plug.

Attention:

If the air supply is cut off at the same time than the extruder or even before, the heater cartridge may be damaged.



8. Maintenance

General rules for all maintenance works:

Pull out mains plug!

Electrical parts to be cleaned without liquids!

Only use original spare parts!

During machine start-up, maintenance works as well as in continuous operation, the appropriate directions of employer's liability insurance association on the subject of accident prevention must be strictly followed.



Please check the connecting cable regularly in view of eventual damage!

We do not accept any liability for damage to persons or machine parts occurred by insufficient maintenance works or improper greasing.

Please take into consideration that regular and thorough maintenance will increase the lifetime of your manual welding extruder and avoid unnecessary standstills during production.

For all repairs at the electrical devices please refer to the high-voltage tests as per VDE 0740.

8.1 Cleaning

After 100 service hours or after 3 months at the latest the cooling slots at the motor housing must be cleaned and the motor blown out with dry compressed air.

8.2 Maintenance works

After 300 service hours or after 6 months at the latest the machine must be thoroughly cleaned, all gear parts and ball bearings washed with solvents and provided with fresh grease. The space between inner and outer ring of ball bearings may only be filled with grease at 1/3 to prevent bearings running hot.

Only use special grease



brand FEIN, Type Sst.I.

After 150 service hours the thrust bearing (item no. 5) of the extruder screw must be dismantled, cleaned and provided with fresh grease.

For the lubrication of the thrust bearing only use



High temperature grease „Shell“

We recommend further eliminating eventually sticking deposits from the screw, for ex. by means of a brass brush. When cleaning the screw please take special care not to damage the chrome layer!

Also retighten all screw connections. Missing or faulty parts must be replaced immediately.

Replace carbon brushes not later than when reduced to 7mm length. We recommend to control the carbon brushes regularly every two weeks, as abrasion of these brushes heavily depends on the prevailing operating conditions.

After insertion of new brushes it has to be checked whether they can be easily moved in their holding device.

If, even after insertion of now carbon brushes, a strong sparking occurs within the collector area, the collector will have to be drawn off. Otherwise there is the danger of heavy wear on the carbon brushes.

8.3 Change of die

Left-hand-threaded and danger of injury by burning!



1. Heat up the machine for approx. 10 minutes.
2. Remove the welding shoe.
3. By means of a spanner, screw the die (item no. 1) out of the extruder cylinder.
4. Screw the new die into the extruder cylinder.
5. Loosen the die by approx. half a rotation.
6. Tighten the die definitely after 5 minutes' time, otherwise there is the danger of damaging the brass threading of the die.

8.4 Change of extruder screw

Only possible with heated screw and therefore danger of injury by burning!



1. Heat up the machine for approx. 10 minutes
2. Empty the machine
3. Pull out mains plug
4. Remove the die (see chapter 8.3)
5. Loosen the screws M4 (item no. 30)
6. Pull off the cylinder from the drive engine in the direction of extrusion.
 7. Remove the Seeger circle ring (item no. 6) by means of special nippers for circles, type i-2.
8. Now pull out the extruder screw with the thrust bearing to the rear side.
9. It is highly recommended, when changing the extruder screw to clean the thrust bearing and to grease it with "high temperature grease shell".
10. Now proceed with the re-assembly of the machine in the opposite order. When mounting the thrust bearing special care must be taken to mount first the bearing ring with the small boring, afterwards the ball bearing cage and finally the bearing ring with the big bore. Please see to it that the feather key of the driving engine and the groove of the extruder screw are in exact alignment.

8.5 Change of welding nozzle

The mounting or change of the welding nozzle may only be affected in heated condition.
Danger of injury by burning!



After loosening of the attachment screw (1) (see picture below)

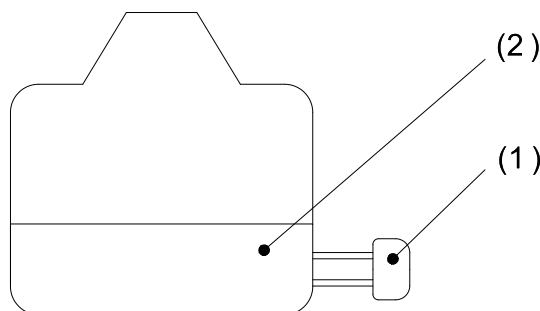

Pull off the welding nozzle
with an appropriate pair of nippers, slightly turning.

The nippers may only have contact with the aluminium base plate (2) of the welding nozzle; otherwise there is the danger of damaging the nozzle.

Please do not remove the welding shoe by pushing it off between heater band and welding nozzle with a sharp object.

In addition to damaging the manual welding extruder or the welding nozzle, there is the danger of electric shock.



After removal of the welding nozzle, the die and the aluminium base plate can be cleaned from adherent material deposits.

To this purpose employ a soft wire brush, for example out of brass.

After remounting and alignment of the welding nozzle please retighten the attachment screw (1) again, but only smoothly - just to keep the welding nozzle stable. If screw is retightened too much, the die may be damaged. Once the system has cooled down, it is well possible that the welding nozzle sticks quite loose in its position. Discovering this, please do not tighten the attachment screw (1) because of the said reasons. The attachment screw (1) must only be retightened once the machine has been heated up again for further use.

9. Defects and their possible reason

DEFECTS	Possible reasons
Machine doesn't discharge uniformly (is pumping) mainly occurs with PP	a): machine is overheated b): screw must be cleaned
Melt is interspersed with bubbles	a): melt temperature is too high b): welding wire is too old or too humid
Machine does not reach sufficient speed	a): melt temperature is too low b): heater band defective
Machine does not run smoothly	a): wear of carbon brushes b): fluctuations on the power supply
No means to regulate melt temperature	regulator or thermocouple defective
Set-point air temperature for preheating is not reached	a): cartridge heater defective b): electronics defective c): insufficient air quantity

10. Spare parts list extruder

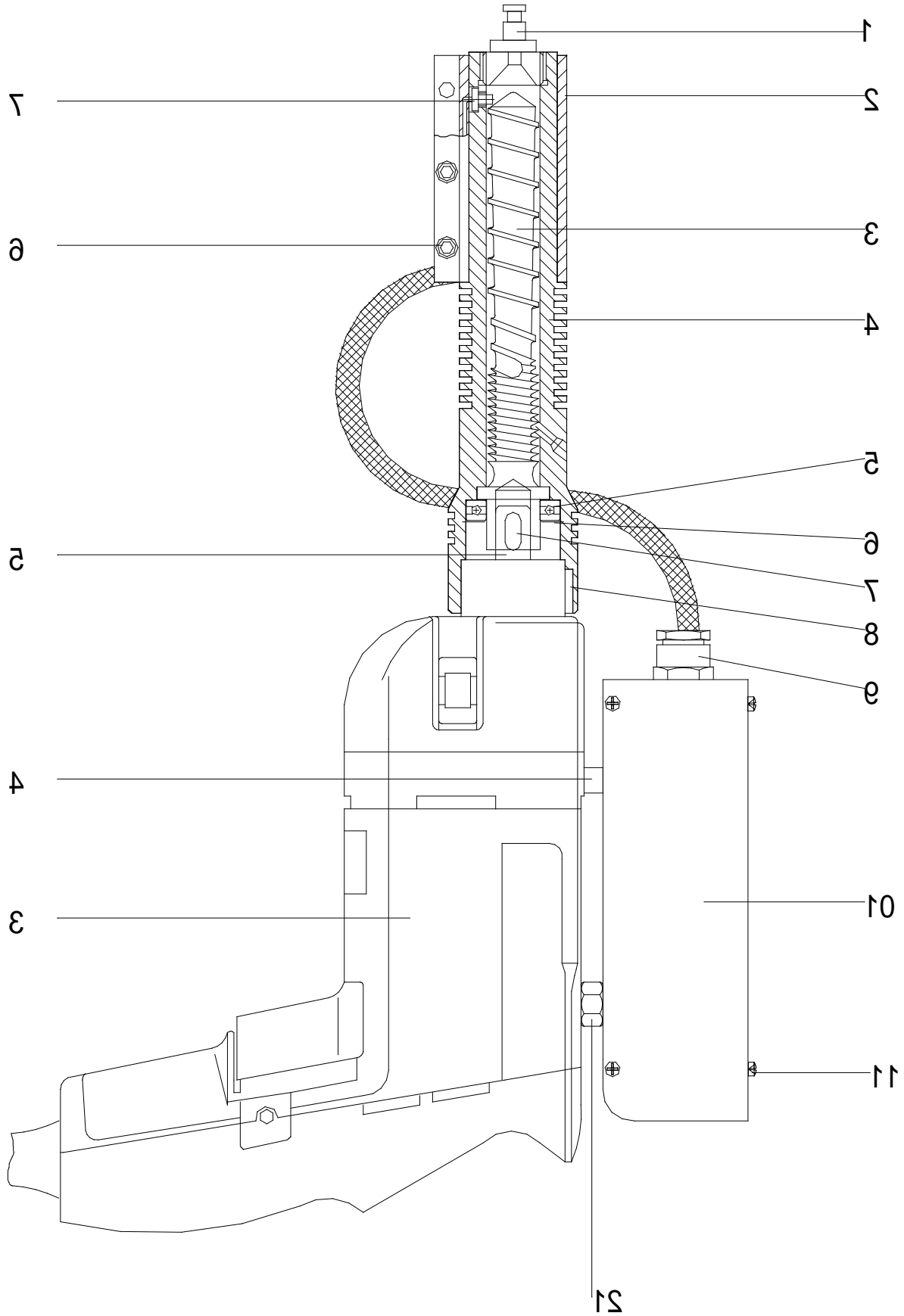

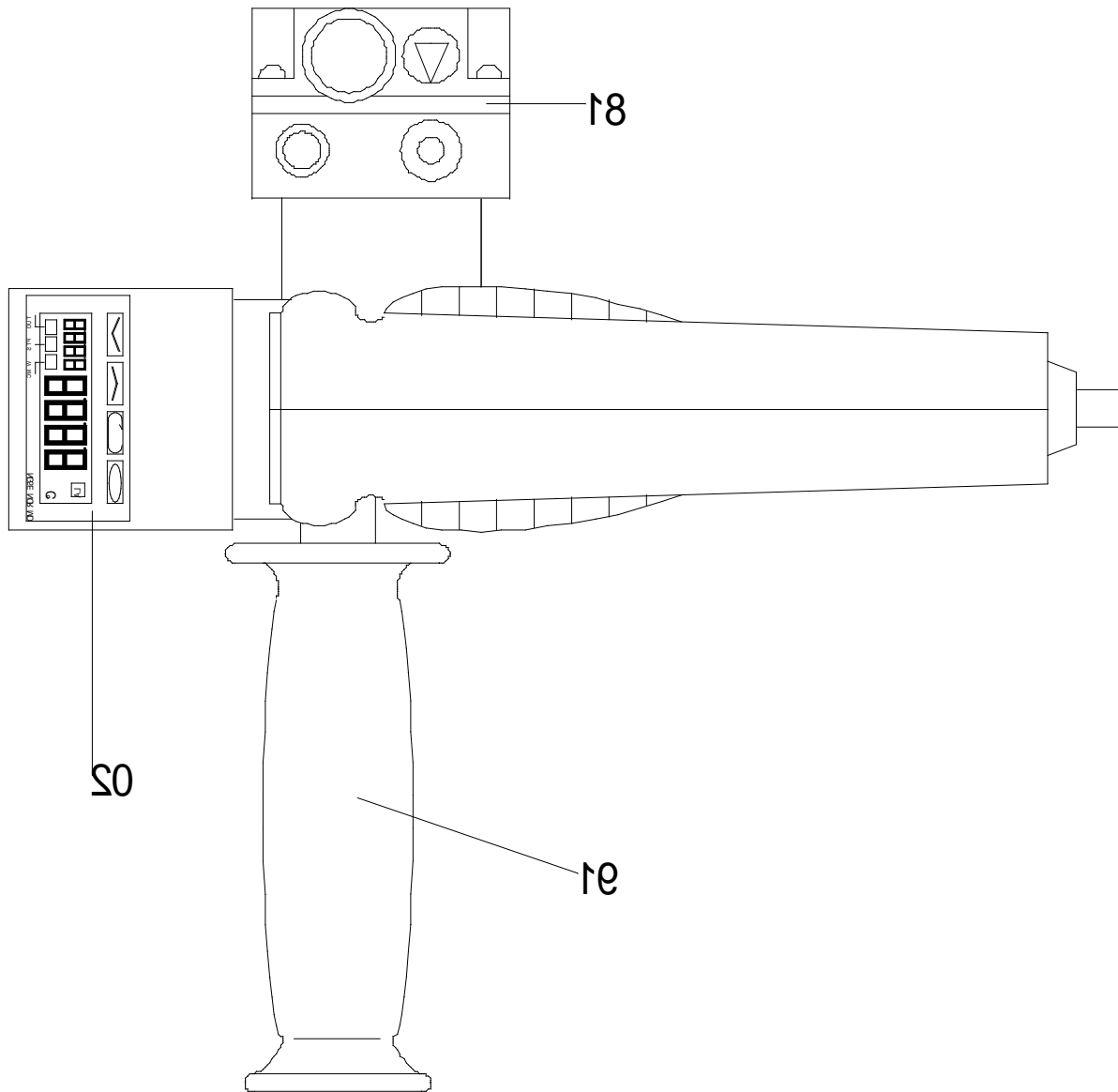

SPARE PARTS LIST FOR MANUAL WELDING EXTRUDER HSK10 DE-Series		
Item	Denomination	Quantity
1.	Die	1
2.	Heater band	1
3.	Extruder screw	1
4.	Cylinder	1
5.	Thrust bearing type 51103	1
6.	Circle ring DIN 472	1
7.	Feather key 5*8	1
8.	Alignment pin	1
9.	Screw connection PG-9	1
10.	Switch box incl. Cover	1
11.	Screw for switch box	8
12.	Passage PG-7	1
13.	Extruder drive Bop 10-2	1
14.	Holding device for switch box	1
15.	Driving shaft	1
16.	Screw connection for heater band complete	1
17.	Thermocouple for mass temperature FeCuNi	1
18.	Air heater	1
19.	Handle M14	1
20.	Regulator Omron E5GN	1
	Further spare parts without illustration	
21.	Tube with oval cross section	1
22.	Seal for oval cross section tube	1
23.	Screw M5*8	2
24.	Screw M5*12	1
25.	Helicoil M5*5	1
26.	Semi-conductor relay 230V, 50W	1
27.	Screw M4*12 galvanized	1
28.	Screw connection PG-7	1
29.	Mains cable	1
30.	Screw M4	2

11. Wiring diagram

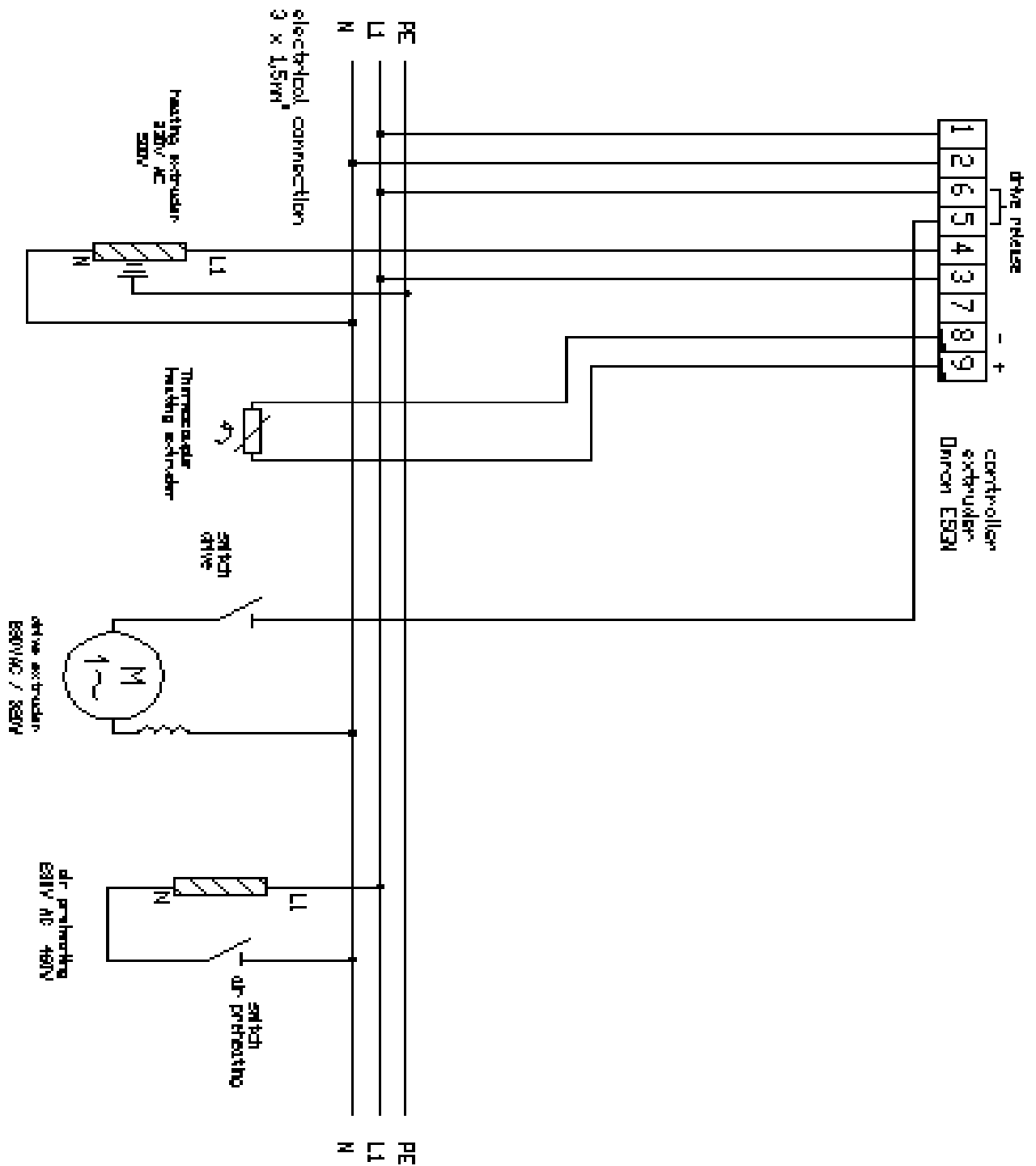

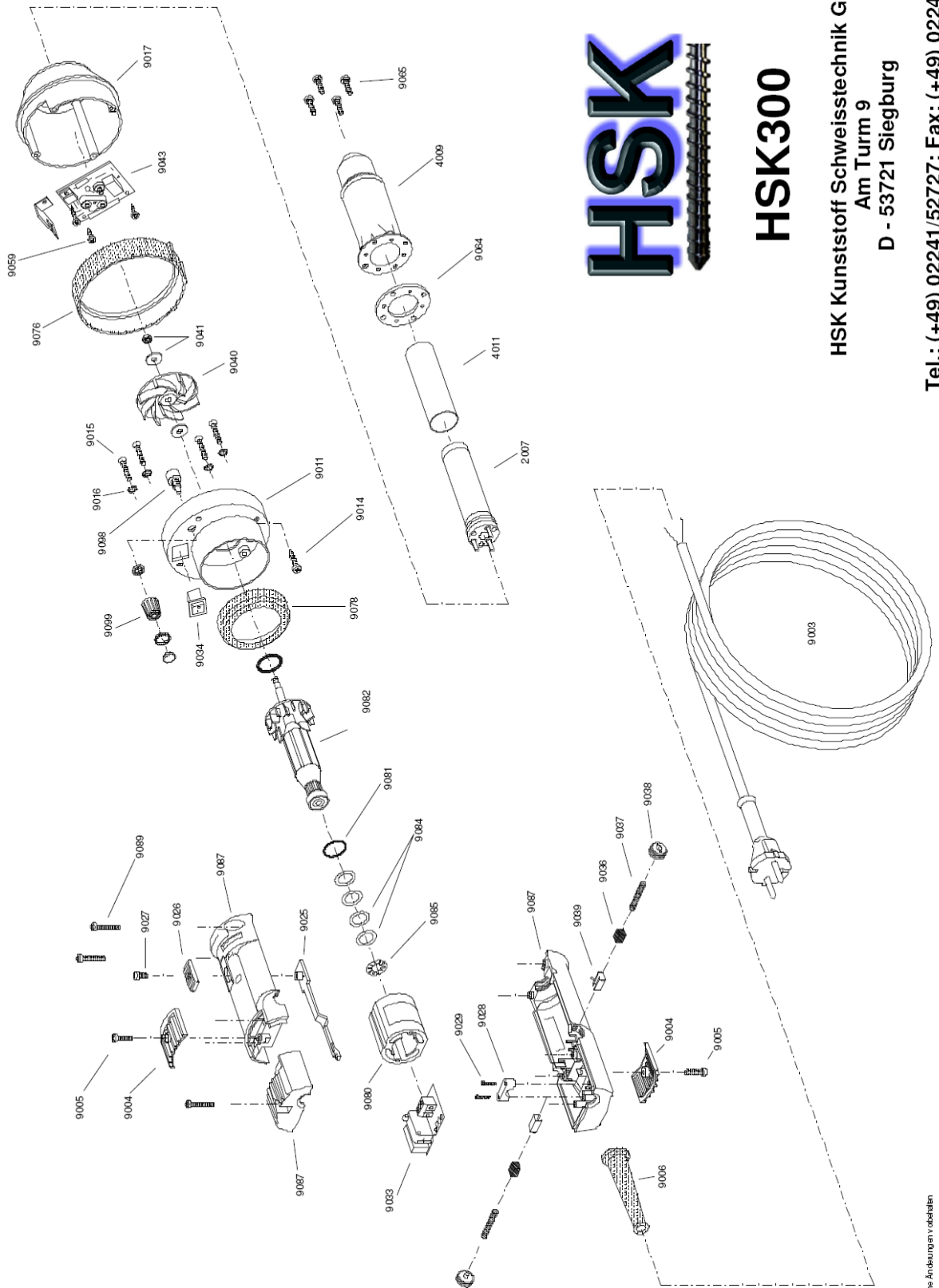

HSK300

HSK Kunststoff Schweißtechnik GmbH
Am Turm 9
D - 53721 Siegburg

Tel.: (+49) 02241/52727; Fax: (+49) 02241/55405

<http://www.schweissextruder.de>

Technische Änderungen vorbehalten

12. Air heater

Please pay attention to the manufacturers operating and maintenance instructions.

For the air supply we recommend to use our compactor DT 4.25. The air generated by this device is much more cleaner and drier compared to compressed air generated by normal compressors. Further more, the energy costs involved represent only a small portion of the production costs of compressed air.

13. Special accessories

- Diverse pipe burner prolongations and sheet dies
- Portable air compactor (400 l/min., 1 bar) to operate air heater
- complete welding nozzle programme for sheet width from 5 mm to 40 mm, suitable for fillet, V and corner welds
- welding nozzle blanks with the following dimensions:
 - 50 mm * 30 mm
 - 57 mm * 40 mm
 - 73 mm * 70 mm
- Special dimensions on request
- welding nozzle preheating
- handle with angle adaptation

Please contact your retailer for further accessories or get in direct contact with HSK.

HSK Kunststoff Schweißtechnik GmbH
Am Turm 9
D – 53721 Siegburg
Germany

Tel.: (+49) 02241/52727; Fax: (+49) 02241/55405

<http://www.schweissextruder.de>

14. Declaration of conformity according to EG regulation 2004/108/EG,
2011/65/EU and 2006/95/EG

The manufacturer: HSK Kunststoff Schweißtechnik GmbH

Am Turm 9
D-53721 Siegburg
Germany

herewith declares that the product

Name of product: hand welding extruder

Machine types: HSK10 D, HSK10 DE

to which refers this declaration complies with the general security and health requirements set forth in the EG regulation 2004/108/EG, 2011/65/EU und 2006/95/EG

For the realization of these security and health requirements of the EG-regulations the following standards were also applied:

EMV: EN 55014-1:2006
EN 55014-2:2006
EN 61000-3-3
EN 61000-3-2

Safety: EN 349

Siegburg, in February 2012



Holger Schmidt
(General manager)

Zubehör Schweißtechnik

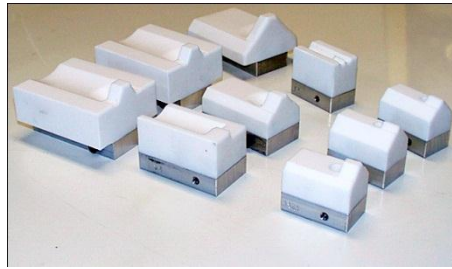

Schweißschuhe

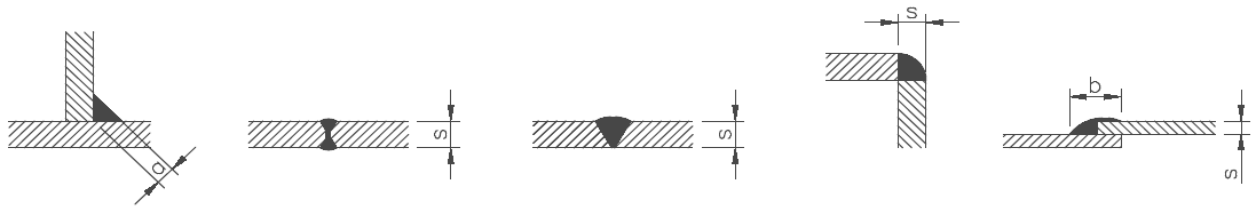

Kehl-naht
A - Schuh

Doppel V-Naht
DV - Schuh

V-Naht
V - Schuh

Ecknaht
E - Schuh

Überlappnaht
U - Schuh



Kehl – Naht									
Plattendicke „s“ in mm	5	8	10	12	15	20	25	30	35
Schweißschuh	A 3,5	A 5,6	A 7	A 8,4	A 10,5	A 14	A 17,5	A 21	A 24,5

Doppel V – Naht									
Plattendicke „s“ in mm	5	8	10	12	15	20	25	30	35
Schweißschuh	X 5	X 8	X 10	X 12	X 15	X 20	X 25	X 30	X 35

V – Naht									
Plattendicke „s“ in mm	5	8	10	12	15	20	25	30	35
Schweißschuh	V 5	V 8	V 10	V 12	V 15	V 20	V 25	V 30	V 35

Eck – Naht									
Plattendicke „s“ in mm	5	8	10	12	15	20	25	30	35
Schweißschuh	E 5	E 8	E 10	E 12	E 15	E 20	E 25	E 30	E 35

Überlapp – Naht									
Plattendicke „s“ in mm	3	5	6	8	10				
Schweißschuh	U 3	U 6	U 6	U 8	U 10				



Typ 1 – 30 x 50mm
 Typ 2 – 40 x 52mm
 Typ 3 – 90 x 70mm

Schweißschuhrohling

PTFE - Block

Alu - Grundplatte