

Installation and Operating Instructions  
 Applies to: SPV8-A- and SPV8- -

## Introduction

The Smartflow SWAP Valve is a simple, manually selectable device that supplies cooling water to the mold during processing or air to purge the water from the mold before a mold change.

The SWAP valve has three positions: WATER, PURGE and VENT. The WATER position is selected for normal processing. The PURGE position is selected to evacuate the water before mold change. The VENT position is selected to bleed-off trapped pressure and drain residual water before a mold change.

An optional spring-loaded locking pin is available to prevent accidental movement of the valve handle.

## Assembly Requirements

1. Apply thread locking compound (Loctite 638 or equivalent) to threaded end of valve handle. Screw valve handle into center disk threaded hole. See figure 1.
3. Thread manual vent into the hole as shown in figure 1. (No additional thread sealant is required. Do not over-tighten.)

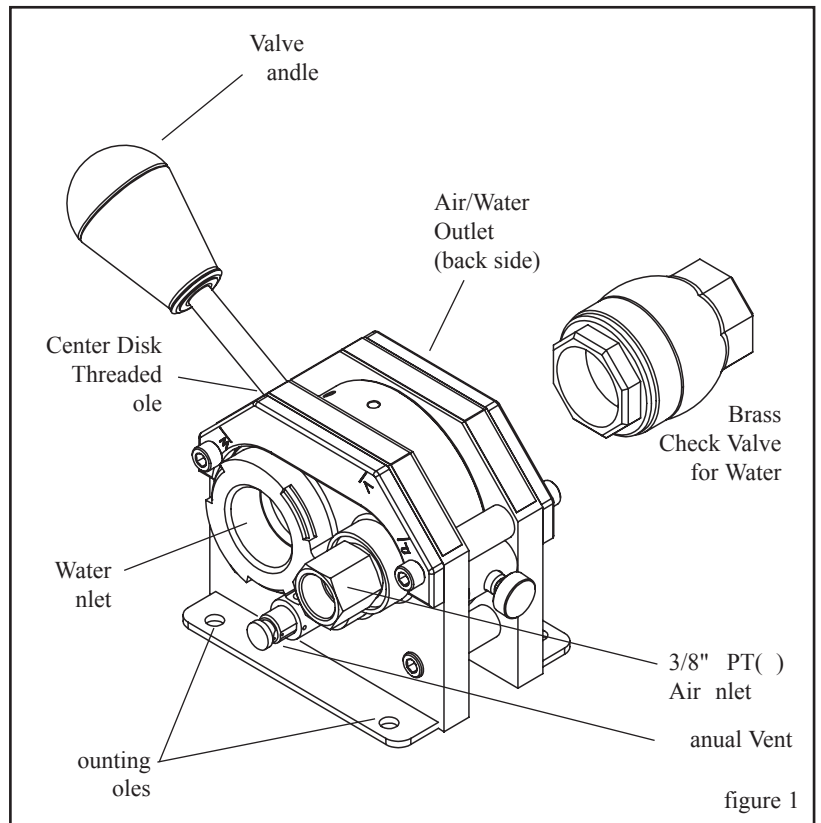

## Installation

The SWAP valve should be mounted to a suitable surface using the mounting holes.

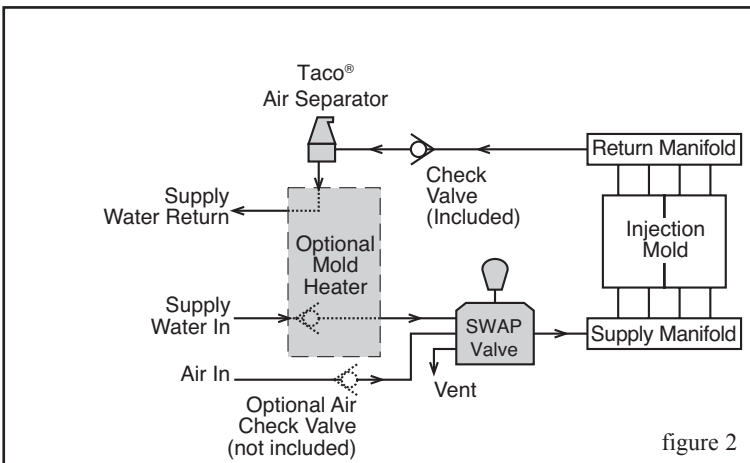

Connect water supply to the Water inlet.

Connect shop air to the 3/8-inch PT ( ) Air inlet with either a permanent or quick-connect fitting.

Connect the Air/Water Outlet to the cooling water Supply manifold.

Install the check valve (included) in the return water line downstream from the Return water manifold as shown in figure 2. The check valve will prevent water from back-flowing into the mold after purging. Depending on your installation, it may be desirable to add a check valve to the air inlet ahead of the SWAP Valve.

In closed loop systems air separator installation is recommended to bleed off residual air introduced by the SWAP Valve. See figure 2. See figure 3 for installation without air separator.

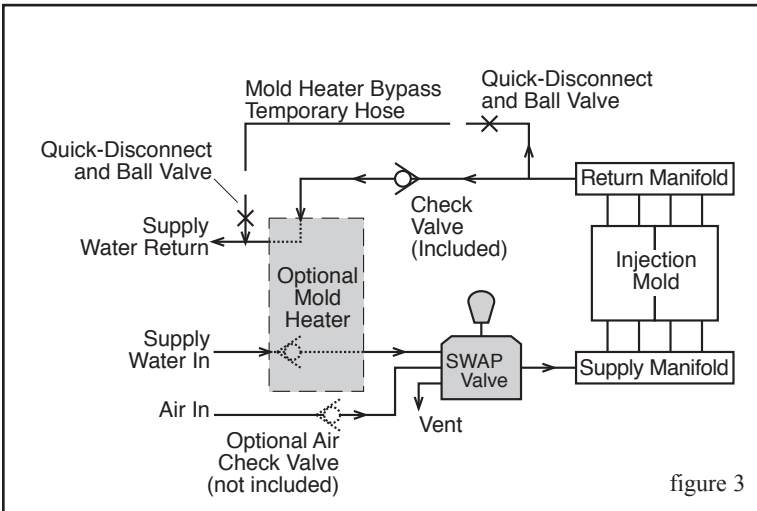

figure 3

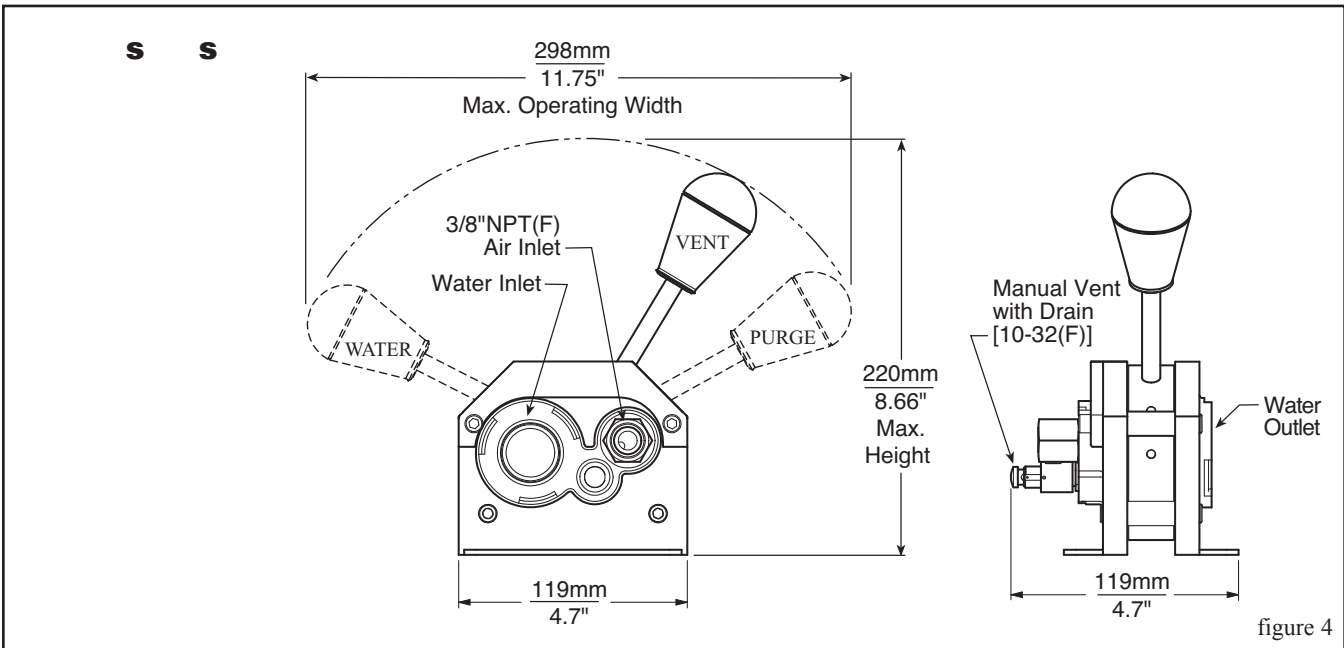

figure 4

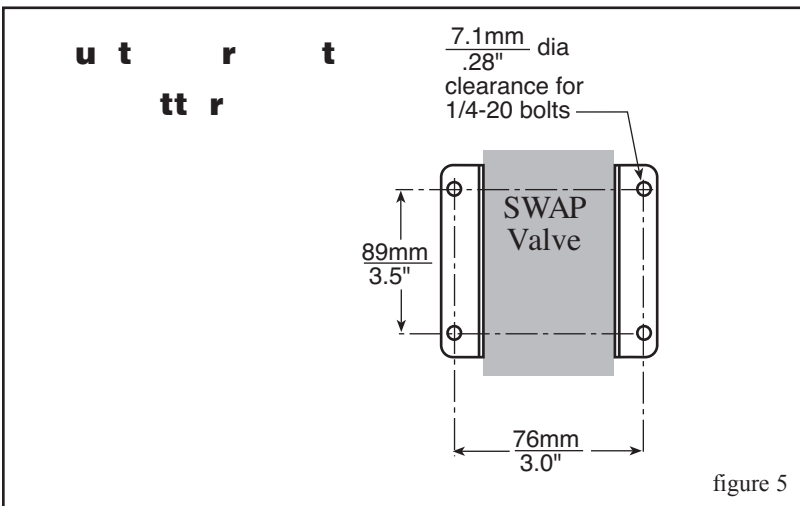

figure 5

part	description
or form l ro ssing	Select . Cooling Water is available to the Supply manifold. Purge Air is blocked.
o v u t ooling t r See ote Below	Select . Purge Air is available to the Supply manifold. Cooling Water is blocked.
o l - r pp r ssur n r in si u l t r	Select . Press Manual Vent-Drain Valve. Purge Air is blocked. Cooling Water is blocked.

---

**Note:** It is possible for the majority of the purge air to rush through the unrestricted water passages, leaving some water in bubblers or baffles. After unrestricted mold passages have been purged, close valves on these passages so more air is available to purge the restricted water passages. It may be necessary to purge longer or to purge restricted passages individually to completely evacuate the water.

*Caution: confirm that the SWAP valve is selected to VENT and that the manual vent button has been pressed to relieve trapped air pressure or residual water before disconnecting any water lines. A drain tube can be connected to the Manual Vent-Drain and run to a suitable drain.*

### **Using a Smartflow Mold Temperature Regulator (MTR)**

1. Stop the press.
2. Note the setting on the calibration scale, then move the knob to the “Flush” position (Clockwise to the stop).
3. Perform the SWAP Purge Procedure (see OPERATION above).
4. On the MTR, return the knob on the calibration scale to the previous position. (It will be necessary to rotate the knob more than one complete turn counterclockwise.)
5. Select Water after the new mold is installed and the cooling water connections are secure.

### **Using a TCU (temperature control unit in a closed loop system)**

We recommend using a temporary bypass hose or TACO Air Separator per figures 2 & 3. Install bypass hose and open ball valves on each end of the bypass before purging the mold (figure 3). An air separator may be installed in the location shown at the highest point possible (figure 2). Your installation may vary.

1. Stop the press.
2. Check the TCU manufacturer’s instruction for Purge position or Bypass instructions.
3. Perform the SWAP Purge Procedure (see OPERATION above).
4. Reset the TCU to the original operating configuration.
5. Select Water after the new mold is installed and the cooling water connections are secure.

## Troubleshooting

Symptom	Corrective Action
Air or water does not flow through the system	<ul style="list-style-type: none"><li>• Verify check valve direction</li><li>• Check that the valve handle is in the correct position</li></ul>
Water leaks from the valve while in operation	<ul style="list-style-type: none"><li>• Replace O-Rings (Contact factory for repair or field replacement procedure)</li></ul>
Mold does not evacuate completely	<ul style="list-style-type: none"><li>• Check air pressure (80 to 125 psi required)</li></ul>

## Replacement/Additional Parts

Description	SPV8 (1-inch)
O-Ring Set .....	PVOSET-100M
Valve Handle Knob.....	PVKB-100
Air Check Valve 3/8".....	PVCV-3
Return Check Valve.....	PVCV-100
Manual Vent.....	S15-2532



Abbeon Cal, Inc.  
1363 Donlon Street Unit 1, Ventura CA 93003-8387

[www.abbeon.com](http://www.abbeon.com) • Phone: 800-922-0977 • E-mail: [abbeoncal@abbeon.com](mailto:abbeoncal@abbeon.com)