



Panel Saw

Owner's Manual

7000, 7000M, 7000HD, 7400, 7400M, 7400XL & 7400XLM



7400 vertical panel saw

Proudly made in the USA



Abbeon Cal, Inc.

Industrial Plastic Working Equipment & Precision Instruments



Read and understand this manual before operating this tool. Failure to follow the safety precautions and instructions can result in serious injury or death. Keep this manual in an accessible and safe location for future reference.

Abbeon Cal, Inc.,
1363 Donlon Street Unit 1, Ventura, CA 93003-8387
800-922-0977 www.Abbeon.com
E-mail: abbeoncal@abbeon.com

A message from all of us at SAFETY SPEED MANUFACTURING:

Thank you for purchasing a Safety Speed Manufacturing (SSM) vertical panel saw. We take pride in building these fine products in the U.S.A.

Each SSM product is designed to give years of dependable service. Your new panel saw was built from the finest components available, and every machine is individually assembled by craftsmen - some of whom have been building these products for more than 25 years. We appreciate you choosing SSM products for your facility.

Team Safety Speed
Ham Lake, Minnesota

Limited Warranty

Safety Speed Manufacturing (SSM) warrants the parts and workmanship of this tool, except for the electric motor(s), for up to three years from the date of purchase (depending on model). SSM will repair or replace, at our discretion, any component that is determined to be defective. Repair or replacement is limited to providing replacement parts from the factory. SSM assumes no responsibility for making repairs on site. Parts returned to the factory must be returned freight prepaid and include a Return Authorization (R.A.) number.

All motors are warranted directly by the motor manufacturer. See local repair and maintenance centers for warranty claims for motors.

Safety Speed Manufacturing assumes no responsibility for any damage or accidents resulting from the misuse of this tool, its misapplication, or failure to follow precautionary safety measures. SSM assumes no responsibility for any consequential damage or loss of production. SSM will not be responsible for claims made for machines that are not used or maintained in the normal course of business, used for applications not intended, or modified in any way. This warranty gives you specific legal rights, and you may also have other rights which vary from state to state. SSM # 763-755-1600.

This manual applies to the following SSM panel saw models:

- | | | | |
|------|-------|--------|---------|
| 7000 | 7000M | 7000HD | |
| 7400 | 7400M | 7400XL | 7400XLM |

Enter your model number and serial number for quick and easy reference when ordering accessories, supplies or parts.

Note: The Model and Serial Number label of the 7000 & 7400 variations can be found on the upper, left side of the frame, when facing the vertical saw (Fig. 1). **NOTE: 7000HD**, label is located on the left, horizontal frame tube.

Model No: _____

Serial No: _____

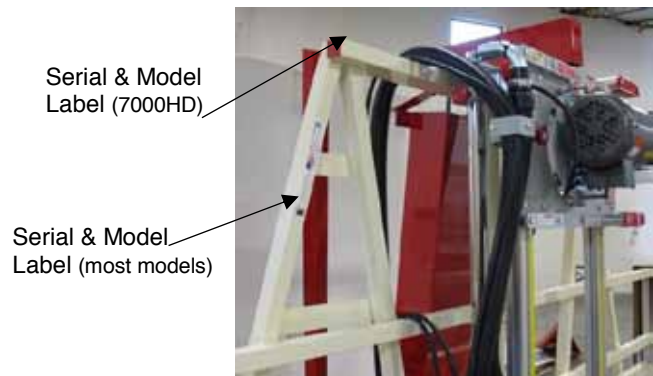

Figure 1: Serial & Model label (7000 shown)

CONTENTS

Safety.....	4
Safety & Warning Label Placement.....	4
Safety & Warning Labels Identified.....	5
Safety Procedures.....	6
Proposition 65 Warning.....	9
Electrical Safety.....	10
Extension Cords.....	11
Short-Circuit Protection.....	11
Vertical Panel Saw Components.....	13
Installation/Set Up.....	14
Tools Required for Installation.....	14
Operating Environment.....	14
Inventory.....	15
Unpacking.....	15
Machine Assembly.....	17
Installing/Changing a Saw Blade.....	20
Rulers.....	24
Kerf Spreader.....	26
Hold Down Bar.....	27
Scoring System.....	29
Operation.....	33
Capacities of the Tool.....	33
Selecting a Saw Blade.....	35
Basic Operating Controls and Functions.....	36
General Operating Tips.....	38
Operating Procedure: Crosscutting.....	38
Operating Procedure: Rip cutting.....	40
Maintenance.....	43
General Maintenance.....	43
Cleaning.....	44
Maintaining the Motor.....	44
Maintaining the Guide Tracks.....	44
Service.....	45
Repairs.....	45
Replacement Parts.....	45
Alignment.....	45
Accessories.....	48
Tools Required for Installation.....	48
Frame Extensions.....	48
Stop Bar.....	49
Quick Stop.....	50
Midway Fence.....	52
Accessory List.....	55
Specifications.....	55

SAFETY

Read and understand this manual before operating this tool. Failure to follow the safety precautions and instructions can result in serious injury or death. Keep this manual in an accessible and safe location for future reference. Electronic copies of this manual are available at www.safetyspeed.com. Printed copies are available by calling SSM **763-755-1600**.



Indicates a hazardous situation which, if not avoided, will result in death or serious injury.



Indicates a hazardous situation which, if not avoided, could result in death or serious injury.



Indicates a potentially hazardous situation, which if not avoided, could result in minor or moderate injury.

Safety & Warning Label Placement

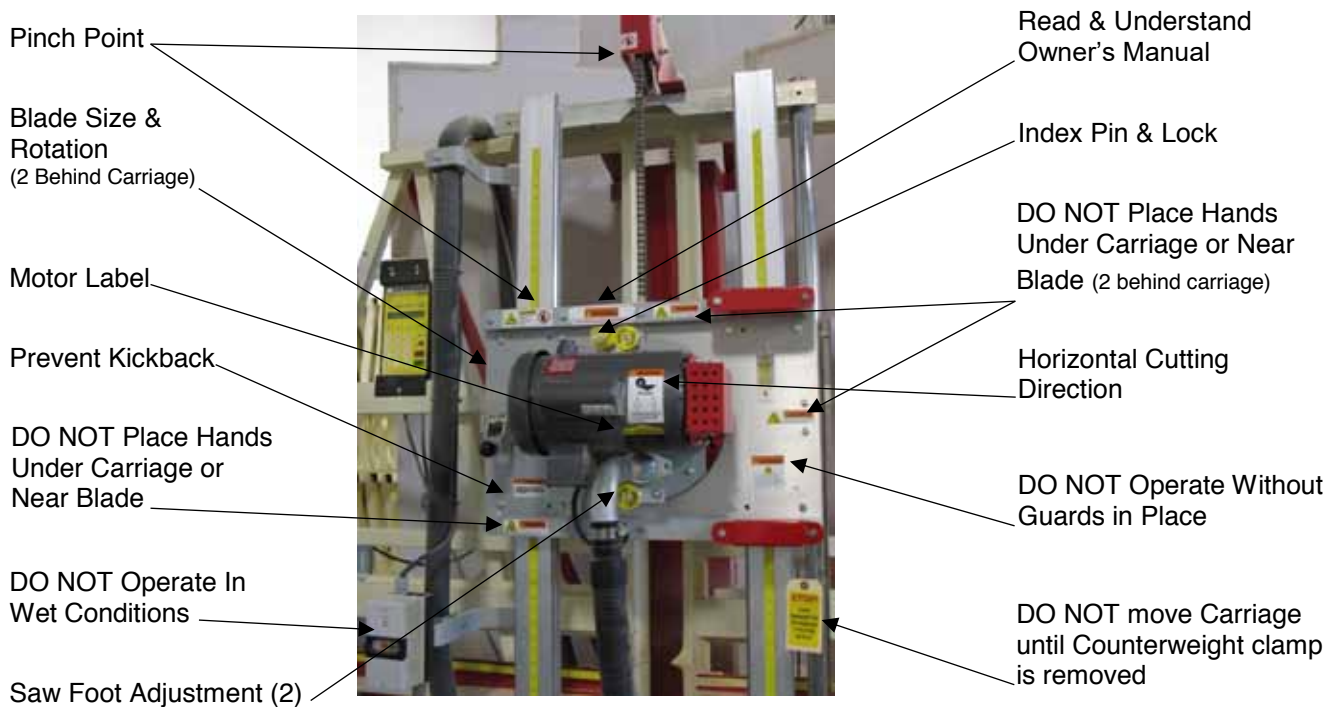

Figure 2: Safety & Warning Label locations, 7400 shown

Safety Warning Labels Identified



Feed Stock In The Direction Of The Arrow



Remove Counterweight Clamp



Do Not Use Without Blade Guard



Read Owner's Manual Before Operating



Read Instructions To Reduce Risk Of Kickback



Do Not Place Hands Under Saw



Do Not Operate In Wet Conditions



Indexing Pin Lock Knob



Install Blade In Direction Of Arrow



Raises & Lowers Saw Foot



Indexing Pin



Keep Hands Clear Of Area To Reduce Risk Of Pinching



Do Not Place Hands Under Saw



When using electric tools, always follow basic safety precautions to reduce the risk of fire, electric shock, and personal injury.

READ AND SAVE ALL INSTRUCTIONS FOR FUTURE USE. Before use, be sure everyone using this tool reads and understands this manual as well as any labels packaged with or attached to the tool.

1. **KNOW YOUR POWER TOOL.** Read this manual carefully to learn your power tool's applications and limitations as well as potential hazards associated with this type of tool.
2. **DO NOT ALLOW UNQUALIFIED PEOPLE TO OPERATE** the tool.
3. **AVOID DANGEROUS ENVIRONMENTS.** Do not use your power tool in rain, damp or wet locations, or in the presence of explosive atmospheres (gaseous fumes, dust, or flammable materials). Remove materials or debris that may be ignited by sparks.



4. **KEEP WORK AREA CLEAN AND WELL LIT.** Cluttered, dark work areas invite accidents. Provide at least 200 watts of lighting at the front work area of the tool. Eliminate all shadows that could interfere with clear viewing of the work area.
5. **DRESS PROPERLY.** Do not wear loose-fitting clothing or jewelry. Wear a protective hair covering to contain long hair, as it may be caught in moving parts. When working outdoors, wear rubber gloves and insulated, nonskid footwear. Keep hands and gloves away from moving parts.
6. **USE SAFETY EQUIPMENT.** Everyone in the work area should **wear safety goggles or glasses with side shields** that comply with current safety standards. Wear hearing protection during extended use and a dust mask for dusty operations. Hard hats, face shields, safety shoes, etc. should be used when specified or necessary. Keep a fire extinguisher nearby.
7. **KEEP BYSTANDERS AWAY.** Keep children and bystanders at a safe distance from the work area to avoid distracting the operator and contacting the tool or extension cord.
8. **MAKE THE WORKSHOP CHILD PROOF** with padlocks, master switches, etc.
9. **NEVER LEAVE THE TOOL RUNNING UNATTENDED.** Turn the power OFF. Do not leave the tool until it comes to a complete stop.
10. **PROTECT OTHERS IN THE WORK AREA** from debris such as chips and sparks. Provide barriers or shields as needed.
11. **SECURE THE WORK.** Use a clamp, vise, or other practical means to hold your work securely, freeing both hands to control the tool.
12. **USE THE RIGHT TOOL.** Do not use a tool or attachment to do a job for which it is not recommended. For example, do not use a circular saw to cut tree limbs or logs. Do not alter the tool, remove guards, or operate the saw when removed from the carriage and frame.
13. **USE PROPER ACCESSORIES.** Using non-recommended accessories may be hazardous. Be sure accessories are properly installed and maintained. Do not defeat a guard or other safety device when installing an accessory or attachment.
14. **CHECK FOR DAMAGED PARTS.** Inspect guards and other parts before use. Check for misalignment, binding of moving parts, improper mounting, broken parts, and any other conditions that may affect operation. If abnormal noise or vibration occurs, turn the tool off immediately and have the problem corrected before further use. Do not use a damaged tool. Tag damaged tools "DO NOT USE" until repaired. Repair or replace a damaged guard or other part. For all repairs, insist on identical replacement parts or factory certified conversions.
15. **REMOVE ALL ADJUSTING WRENCHES AND TOOLS** from the tool before turning it on. Make this a habit.
16. **GROUND YOUR TOOL.** See "Electrical Safety," page 10.

17. **AVOID ACCIDENTAL STARTING.** Be sure your tool is turned off before plugging it in. Do not use the tool if the power switch does not turn it on and off. Observe correct Lockout/Tagout procedures when performing maintenance on the tool.
18. **DO NOT FORCE THE TOOL.** Your tool will perform best at the rate for which it was designed. Excessive force only causes operator fatigue, increased wear, increased risk of binding or sudden breakage, and reduced control.
19. **KEEP HANDS AWAY FROM ALL CUTTING EDGES, MOVING PARTS AND PINCH POINTS.**



20. **DO NOT ABUSE THE CORD.** Never unplug the cord by yanking it from the outlet. Pull the plug rather than the cord to reduce the risk of damage. Keep the cord away from heat, oil, sharp objects, cutting edges, and moving parts.
21. **DO NOT OVERREACH. MAINTAIN CONTROL.** Keep proper footing and balance at all times. Maintain a firm grip.
22. **STAY ALERT.** Watch what you are doing, and use common sense. Do not use a tool when you are tired, distracted, or under the influence of drugs, alcohol, or any medication causing decreased control.
23. **UNPLUG THE TOOL/DISCONNECT POWER** when it is not in use, before changing items such as blades and before performing recommended maintenance. Observe appropriate Lockout/Tagout procedures.
24. **MAINTAIN TOOLS CAREFULLY.** Keep handles dry, clean, and free from oil and grease. Keep cutting edges sharp and clean. Follow instructions for lubricating and changing accessories. Periodically inspect tool cords and extension cords for damage. Have damaged parts repaired or replaced.
25. **MAINTAIN LABELS AND NAMEPLATES.** These carry important information. If unreadable or missing, contact Safety Speed for a free replacement.



26. **AVOID KICKBACK.** Kickback is a violent reaction to a pinched or binding saw blade. It throws the saw upward when crosscutting and throws the work piece out when ripping. Firm control, proper support of the work piece, and concentration on the job are essential to reduce the risk of injury from kickback:
 - a. **KEEP SAW BLADE CLEAN AND SHARP.** A dull or improperly sharpened blade produces a narrow kerf and is likely to be pinched by the work piece. Any blade with a small set, even though sharp, may be likely to kick back. A dull blade encourages you to force the saw, causing reduced control and blade binding. The excessive friction generated can cause the blade to warp or bind. Use only blades that are recommended for use with your tool. Do not use blades with mounting holes that are not the correct size or shape. Never use defective or incorrect blade flanges or bolts. Be sure the blade bolt is tight. Select the proper blade for the application. Blade speed specifications must be at least as high as the nameplate RPM.
 - b. **DO NOT FORCE THE TOOL.** Let the saw do the work. A saw is more easily controlled and will do a better job when used in the manner for which it was designed.

- c. **SECURE WORK PROPERLY.** If a piece is supported on both sides of the cut in such a way that it allows the material to bow and pinch the blade, it may produce kickback. Do not cut pieces smaller than the saw carriage. Support large panels properly.
 - d. **IF THE BLADE BINDS, TURN SAW OFF!** The saw or work piece may kick back. Keep hands, body, and bystanders out of the path of the blade and material.
 - e. **STAY ALERT.** Watch what you are doing and use common sense. Do not allow yourself to be distracted. Do not operate the tool when you are tired or under the influence of drugs or alcohol. Hold the tool and material firmly and exercise control at all times. Position yourself and co-workers out of the kickback path. Repetitive cuts that lull you into careless movements can also cause kickback. A brief “stretch” may be all that is necessary to avoid a problem.
 - f. **RESTARTING IN MID-CUT.** If the saw is stopped in mid-cut, **TURN SAW OFF!** Allow the blade to stop. Then back up the saw (if crosscutting) or the board (if rip cutting) before restarting.
 - g. **IF THE BLADE STALLS, TURN SAW OFF! DO NOT TURN THE SWITCH ON AND OFF.** A dull blade or excess pressure may cause stalling. **TURN OFF** the switch immediately if the blade binds or the saw stalls, and remove the saw from the cut.
 - h. **AVOID CUTTING NAILS OR OTHER FASTENERS.** Inspect for and remove all metal fasteners before cutting.
 - i. **SUPPORT THIN MATERIAL.** Large sheets such as paneling, Formica, etc., tend to warp or sag and must be well supported over their entire length to avoid pinching the blade. The hold down bar is recommended for this application.
27. **HANDLE THE COUNTERWEIGHT WITH CARE.** The counterweight chain is under tension. See page 17. Do not pull on the chain by hand or attempt to disassemble or repair the counterweight. Replacement counterweights can be purchased directly from Safety Speed, or an authorized dealer.



- 28. **DO NOT USE PUSH STICKS.**
- 29. **CROSSCUTTING & CROSSROUTING (VERTICAL CUTTING) MUST ALWAYS BE DONE FROM THE TOP DOWN.** Raise the saw carriage to the uppermost position on the guides and lock it into position with the carriage lock whenever the tool is not in use. See “Operating Procedure: Crosscutting”, for more information.
- 30. **RIPPING (HORIZONTAL CUTTING) MUST ALWAYS BE DONE WITH THE DIRECTION OF THE ARROW.** Raise the saw carriage to the top of the guides and lock it into position with the carriage lock whenever the tool is not in use. See “Operating Procedure: Rip cutting”, for more information.
- 31. **ALWAYS WAIT FOR THE BLADE TO STOP COMPLETELY BEFORE CHANGING POSITIONS.** Unplug the tool before transporting or moving it.
- 32. **DO NOT PLACE YOUR HANDS ON OR UNDER THE SAW CARRIAGE OR IN THE PATH OF THE BLADE.** Do not try to retrieve a piece of cut material while the blade is rotating. This symbol is to remind you:



- 33. **DO NOT DEFEAT THE GUARDS OR OPERATE THE TOOL WITHOUT THE GUARDS IN PLACE.** Do not remove the saw motor from the plate.

34. NEVER STAND ON THE TOOL. Serious injury could occur if the tool is tipped or if you unintentionally contact the cutting tool.
35. DIRECTION OF FEED. Always feed work into the blade or cutter against the direction of the rotation of the blade or cutter.
36. HOME CENTERS AND COMMERCIAL LOCATIONS should check with their local electrical contractor to be sure the proper amount of electrical power (volts/amperes) will be available for this machine during all operating hours and conditions. Be aware of any special electrical safety requirements for this machine (examples: key lock offs, timers, coded security, touch pads, disconnects, or time lockouts) required by local codes.
37. DISCONNECT AND LOCK THE POWER OFF before changing saw blades or making any adjustments.
38. BEFORE CONNECTING THE SAW MOTOR TO THE POWER SUPPLY BE SURE THE MOTOR SWITCH IS IN THE OFF POSITION.
39. KEEP THE CARRIAGE LOCK SECURELY TIGHTENED when the machine is not in use.
40. DO NOT PLACE HANDS UNDER CARRIAGE OR IN LINE WITH CARRIAGE TRAVEL. Be aware of potential pinch points at top of saw carriage. Only hold or operate saw with designated handles. Do not place hands under carriage or in-line with carriage travel.



41. REFER TO PAGE 5 FOR WARNING LABEL IDENTIFICATION.

Please Read Before Operating the Saw



Some dust created by power sanding, sawing, grinding, drilling, and other construction activities contains chemicals known to cause cancer, birth defects or other reproductive harm. Some examples of these chemicals are:

- Lead from lead-based paint
- Crystalline silica from bricks and cement and other masonry products, and
- Arsenic and chromium from chemically treated lumber.

Your risk from these exposures varies, depending on how often you do this type of work. To reduce your exposure to these chemicals: work in a well ventilated area, and work with approved safety equipment, such as those dust masks that are specifically designed to filter out microscopic particles. **For more information go to www.P65Warnings.ca.gov/wood**

Electrical Safety



Improperly connecting the grounding wire can result in the risk of electric shock. Check with a qualified electrician if you are not sure that the outlet is properly grounded. Do not modify the plug provided with the tool. Never remove the grounding prong from the plug. Do not use the tool if the cord or plug is damaged. If damaged, have it repaired by a qualified electrician before use. If the plug will not fit the outlet, have a proper outlet installed by a qualified electrician.

Some machines are equipped with a polarized plug (one blade is wider than the other). This plug will fit in a polarized outlet only one way. If the plug does not fit fully in the outlet, reverse the plug. If it still does not fit, contact a qualified electrician to install a polarized outlet. Do not change the plug in any way. Double insulation eliminates the need for the three wire grounded power supply system mentioned above.

Do not expose your tool to rain or wet conditions. Water entering a power tool will increase the risk of electric shock.



For best performance and to prevent damage use a dedicated electrical circuit for all SSM tools.

The plug must be connected to a properly grounded outlet (Fig. 3) If the tool should electrically malfunction or break down, grounding provides a low-resistance path to carry electricity away from you, reducing the risk of electric shock.

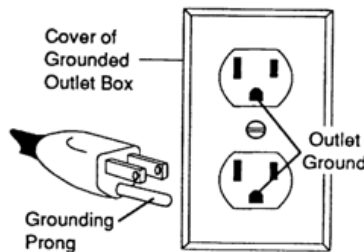

Figure 3: Grounded Plug and Outlet

The grounding prong on the plug is connected through the green wire inside the cord to the grounding system in the tool. The green wire in the cord must be the only wire connected to the tool's grounding system and must never be attached to an electrically "live" terminal.

Your tool must be plugged into an appropriate outlet, properly installed and grounded in accordance with all codes and ordinances. The plug and outlet should look like those in Figure 3.

Figure 4 illustrates a temporary adapter available for connecting grounded plugs. The green rigid ear or lug extending from the adapter must be connected to a permanent ground such as a properly grounded outlet box or receptacle. Simply remove the center screw from the outlet, insert the adapter and reattach the screw through the green grounding ear to the outlet. If in doubt of proper grounding, call a qualified electrician. A temporary adapter should only be used until a qualified electrician can install a properly grounded outlet. The Canadian Electrical Code prohibits the use of temporary adapters.

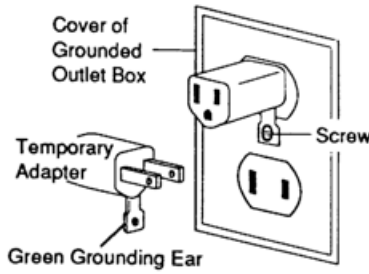

Figure 4: Temporary Grounding Adapter

Extension Cords

Extension cords are not recommended. If an extension cord is used, please adhere to the following suggestions. Grounded tools require a three-wire extension cord. As the distance from the supply outlet increases a heavier-gauge extension cord must be used. Extension cords with inadequately sized wire causes a serious drop in voltage, resulting in loss of power and possible motor damage. Refer to Table I below to determine the required minimum wire size.

Table I: Recommended Minimum Wire Gauge for Extension Cords

Nameplate Amps	Extension Cord Length*					
	25'(7.6m)	50'(15m)	75'(23m)	100'(31m)	150'(46m)	200'(61m)
< 5	16	16	16	14	12	12
5 - 8	16	16	14	12	10	—
8 - 12	14	14	12	10	—	—
12 - 15	12	12	10	10	—	—
15 - 20	10	10	10	—	—	—

* Based on limiting the line voltage drop to 5V at 150% of rated amperes.

— Not recommended

The smaller the gauge number of the wire, the greater the ampacity (capacity) of the cord. For example, a 14-gauge cord can carry a higher current than a 16-gauge cord.

Guidelines for Using Extension Cords

For longest motor life and optimum performance extensions cords are not recommended.

If you are using an extension cord outdoors, be sure it is marked with the suffix "W-A" ("W" in Canada) to indicate that it is acceptable for outdoor use.

Be sure your extension cord is properly wired and in good electrical condition. Always replace a damaged extension cord or have it repaired by a qualified person before using it.

Protect extension cords from sharp objects, excessive heat, and damp or wet areas.

Short-Circuit Protection



Only qualified technicians should make electrical connections. Confirm power is OFF/Disconnected before making connections.

This tool must only be wired into a dedicated circuit that has a short-circuit protection device which is located ahead of the equipment in the circuit, in accordance with local codes.

General guidelines are as follows:

2 HP, 220 Volt, Single Phase: min. 15 Amp circuit protection.

3 HP, 208 Volt, Three Phase: min. 10 Amp circuit protection.

3 HP, 440 Volt, Three Phase: min. 5 Amp circuit protection.

These models can include: 7000, 7000M, 7000HD, 7400, 7400M, 7400XL & 7400XLM

Reference your Motor Label (Pg. 4, Fig. 2) and your local codes before installation.

Electrical Connections

The 7000 and 7400 series vertical panel saws require a dedicated circuit that meets the requirements of the saw motor and local codes. Connect the power cord from the dust collector to a circuit that meets the requirement of the dust collector and all local codes.

Electrical connections should only be completed by a qualified technician in accordance with all local codes. Each model panel saw comes with a cord that requires connecting to a dedicated circuit with either a *disconnect* (hard wired) or a *plug* to be used with a receptacle. The electrical configuration of the main motor will determine the correct circuit and connection (size and type). See Motor Label for specific electrical information (Pg. 4, Fig. 2).

NOTE: Typical motor configurations:

2HP, 208-230 V, Single Phase motor is equipped with a 14-3 cord

3HP, 208-230 V, Three Phase motor is equipped with a 14-4 cord

3HP, 440-460 V, Three Phase motor is equipped with a 14-4 cord

READ AND SAVE ALL INSTRUCTIONS FOR FUTURE REFERENCE



Vertical Panel Saw Components

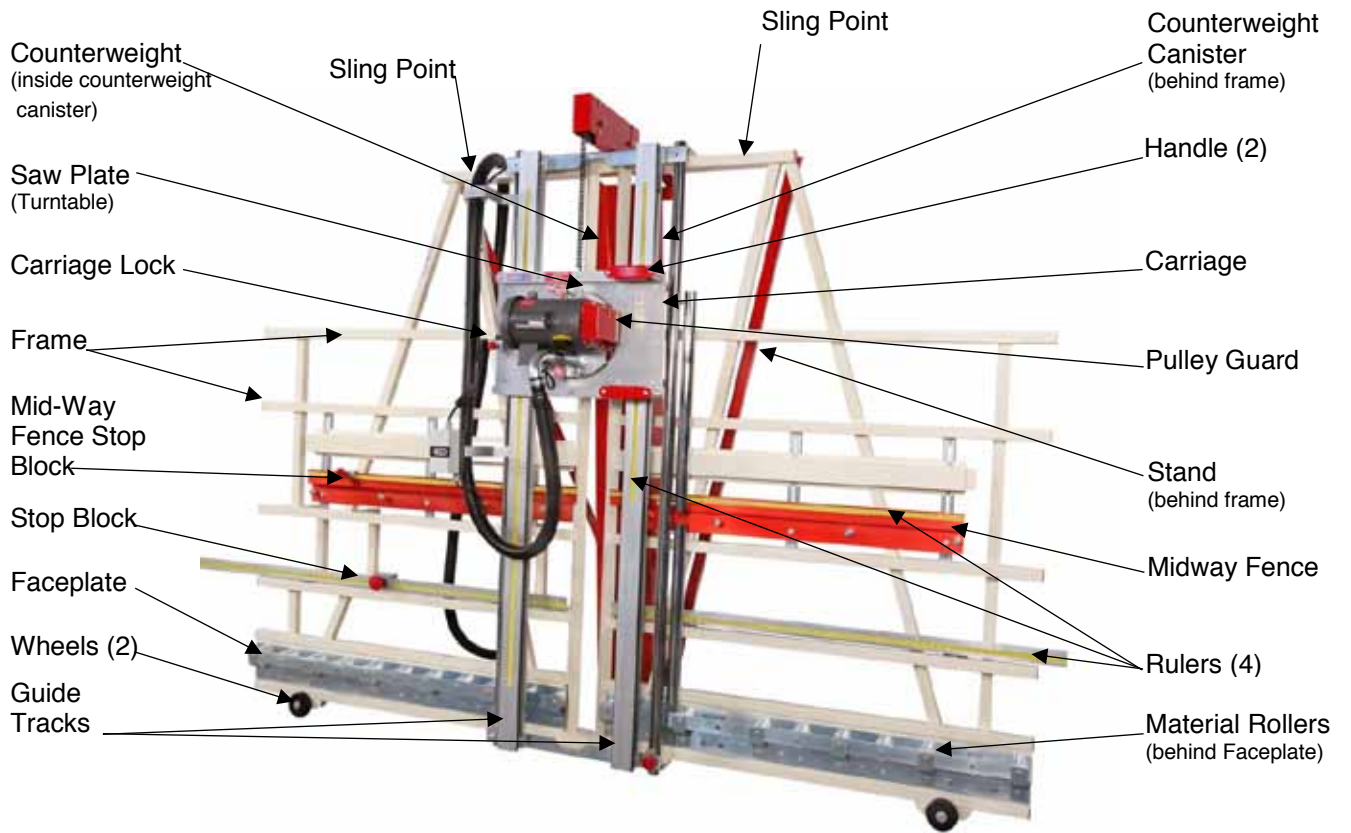

Figure 5: Vertical Panel Saw reference guide, 7400 shown

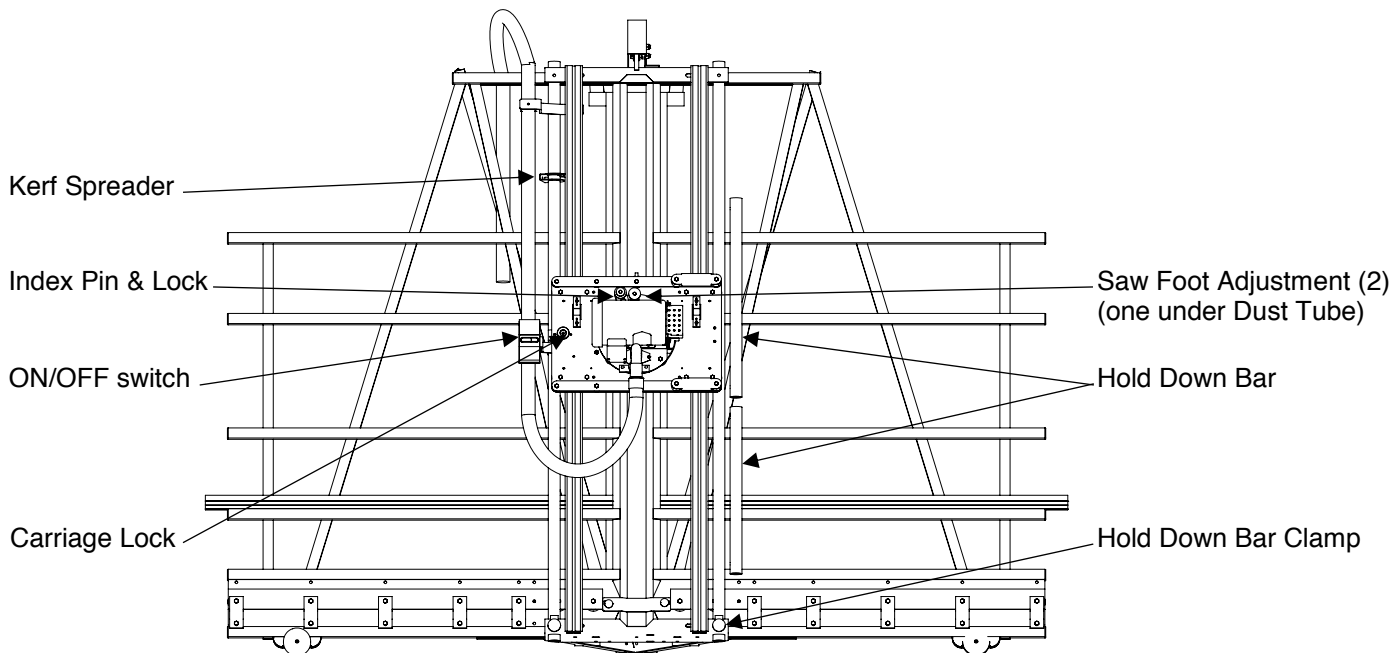

Figure 6: Vertical Panel Saw reference guide, 7000 shown

INSTALLATION/SET UP

Your Safety Speed saw comes from the factory assembled and aligned. You will only have to mount the following parts before you can run these tools:

- Saw Blade
- Wheels
- Quick Stop with Ruler, left extension (except 7000HD)
- Wire machine to circuit (see **Electrical Connections** page 12)

If any optional accessories, (e.g. Vacuum, Laser, etc.) were ordered, assembly instructions will be packed with that item and many are repeated at the end of this manual, (Pg. 48).

Tools Required for Installation

NOTE: Additional tools may be required for installing accessories or making adjustments.

- 3/8" nut driver or socket & ratchet
- 9/16" wrench
- 3/4" wrench
- Two 9/16" blade wrenches, included
- Wiring tools and supplies

Operating Environment

For safe operation, install the tool in an area that is well lit. Eliminate all shadows that could interfere with clear viewing of the work area.

Do not locate the tool in a damp or wet location, or a location where it may be exposed to rain.



Do Not Operate In Wet Conditions

SSM recommends installing an optional Vacuum (Pg. 55).

Avoid explosive atmospheres (gaseous fumes, dust, or flammable materials).

Secure the area so that children and bystanders are kept a safe distance from the work area. Provide barriers and shields as needed.

NOTE: The average noise level of SSM saws is less than 80 db.

Inventory

Each model includes the frame, motor and counterweight. The Saw Blade, Stops, Manual, Blade Wrenches and Wheels (when applicable) are included in a separate box or boxes and attached to the saw frame. Accessories may be packaged and included with saw frame or shipped separately. Carefully remove and inspect all items before assembly and operation.



Figure 7: Packaged saw and boxes (7000 shown)

Unpacking

1. Removing plastic sheeting, protective cardboard, and wood crating. NOTE: Uncrating methods vary by model and accessories.



Caution: Have a helper “spot” or maintain saw frame for the next steps.

2. Remove wood crate by cutting (a reciprocating saw is used as an example) the wood frame along the **outside/front** corners (Fig. 8) being careful not to damage panel saw. Cut around base.

NOTE: Do not cut through (across) crate base.



Figure 8: Cutting front/side of wood crate



Figure 9: Uncrating saw, cleat removal

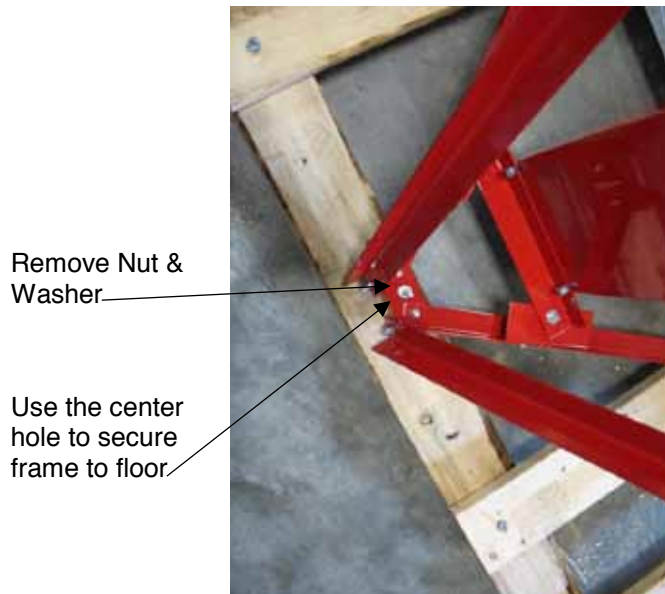

Figure 10: Uncrating saw, nut removal

3. Cut top of crate near saw frame, to release crate. Remove top of crate and any cross members to release saw from crate.
4. Remove front of wood crate as it should be loose from saw frame and crate.
5. One or more boxes of parts are attached to the frame. Remove the box or boxes for later installation.
6. Remove (pry, cut or unscrew) two wood cleats (one on each side of saw frame) holding bottom ends of saw frame to crate (Fig. 9).
7. Remove nut from center bolt holding back leg of saw stand to crate (Fig. 10).

Note: Only remove nut from center bolt securing saw stand to crate.

8. Panel Saw can be lifted from crate by several helpers or using slings through horizontal saw frame (Pg. 13, Fig. 5) and a fork lift, being careful not to damage saw.
9. Place in the desired and secure location. Attach wheels, (see Machine Assembly). Bolt stand to floor, using the same hole in stand used to secure frame to pallet (Fig. 10). The stand will correctly support the tool under normal operating conditions.



A freestanding saw must be located away from areas where it could be accidentally tipped over.

Machine Assembly



To reduce the risk of injury or damage to components, do not attempt to disassemble or repair the Counterweight. Do not pull on the Counterweight roller chain. The chain is under strong force: The unit must be properly assembled and clamp removed before operating machine to prevent damaging the Counterweight or Saw Carriage.

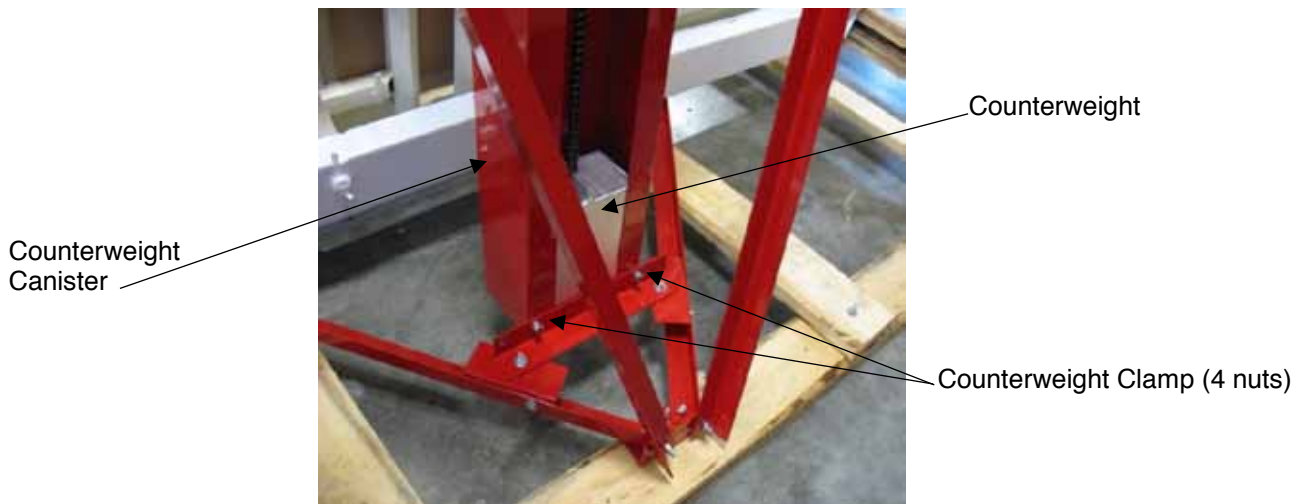

Figure 11: Counterweight assembly

Counterweight

1. Remove two nuts (four total) on each side of Counterweight clamp (Fig. 11).
2. Remove the clamp (from underneath) with two bolts from inside of Counterweight Canister.

NOTE: Counterweight Clamp removal is easier when panel saw is on shipping skid.



Do not remove the bolt and nut from the Counterweight pulleys.

Frame Wheels

The Frame Wheels allows vertical panel saws to be rolled from one location to another in the shop. It includes two wheels and mounting fasteners.

Installation:



Unplug tool before making adjustments or installing components or accessories.

Observe appropriate Lockout/Tagout procedures to insure the tool cannot accidentally be powered.

Bolt one wheel to each end of the frame as shown in figures 12 & 13.

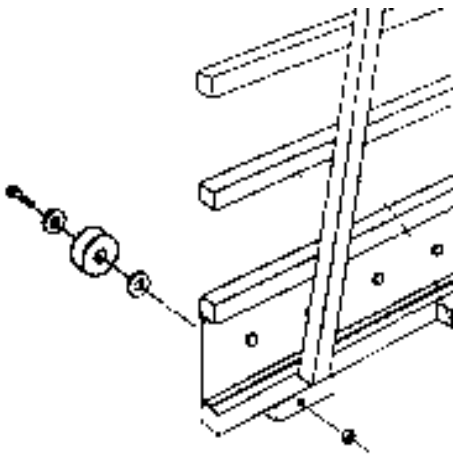

Figure 12: Installing the Wheels
(viewed from rear of frame)



Figure 13: Wheels installed

Quick Stop Extension (except 7000HD)



Unplug Saw before adjusting.

Observe appropriate Lockout/Tagout procedures to insure the tool cannot accidentally be powered.

Assembly:

1. Remove Quick Stop, and aluminum angle extrusion, from back of saw frame. It was temporarily attached to the back of saw frame for safe shipment (Fig. 14).

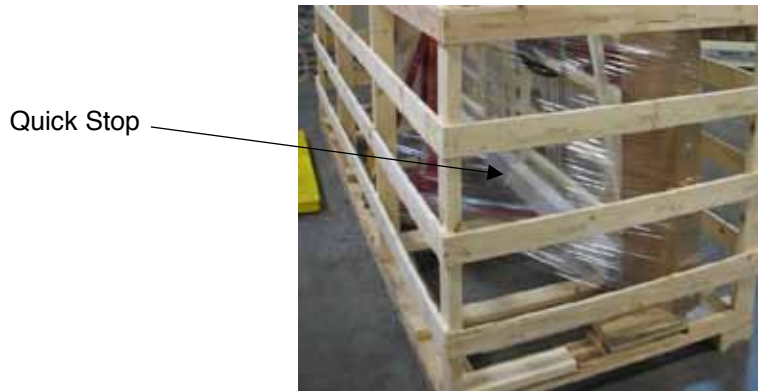

Figure 14: Quick Stop

- Place the Quick Stop on the second to lowest horizontal tube, on the left side of frame (when facing saw, Fig. 15).

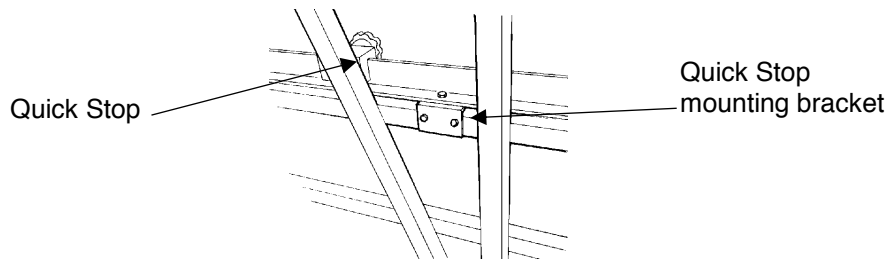

Figure 15: Quick Stop (from back)

- Attach by aligning mounting brackets to pre-drilled holes in back of horizontal tube. Install four (included) self-tapping hex head bolts and tighten (Fig. 15)
- Measure from the blade and adjust Quick Stop measuring tape by sliding it in the extrusion (Fig. 16). Adjust tape by grabbing extrusion with both hands and sliding tape with thumbs.

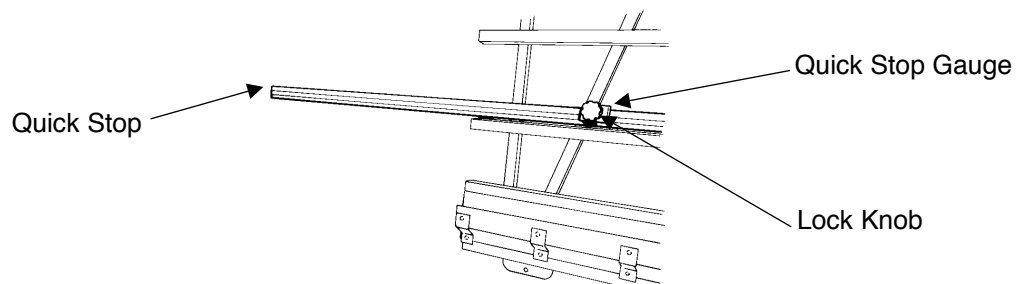

Figure 16. Quick Stop installed

Operation:

- Position Quick Stop Block at the desired cut length, as indicated by the Quick Stop measuring tape, and secure by tightening the Lock Knob (Fig. 16).
- Raise the Saw Carriage to the top of the Guide Tracks.
- Slide material behind Saw Carriage and hold it firmly against Stop Block.



To reduce the risk of injury, do not place your hands on or under the carriage or in the path of the saw blade.

4. Cut the material with a smooth, continuous down stroke of the Saw Carriage.



Do not use panel saw motor for applications not intended. Do not use saw motor removed from the carriage, plate or base for any application. The saw motors are engineered for SSM and built specifically for the intended use as a vertical panel saw.



Installing/Changing a Saw Blade:

1. Observe appropriate Lockout/Tagout procedures to insure the tool cannot accidentally be powered.
2. Select the correct blade for your needs. Refer to “**Selecting a Saw Blade**”, page 35.

IMPORTANT: Improper blade selection can result in reduced tool life, inaccurate, poor quality cuts, and safety risks. Consult with your machinery dealer or with our customer service department (763-755-1600) to determine the best blade for your cutting needs.

NOTE: It is a good idea to have spare blades available to prevent downtime.

3. On models with frame filler inserts, slide right side panel, fourth from bottom, to the right (Fig. 17).



Figure 17: Removing Frame Filler Insert (7000HD shown)

4. On models with frame filler inserts, remove center filler, held in place with magnets (earlier models were screwed in place) (Fig. 18, A & B). This will provide access to the arbor nut and arbor shaft.



Figure 18, A & B: Removing Center Frame Filler Insert (7000HD shown)

5. Move Saw Carriage to the opening created by sliding the frame filler insert or to a convenient working height if your model does not have the inserts. Lock the Carriage Lock (Fig. 19).

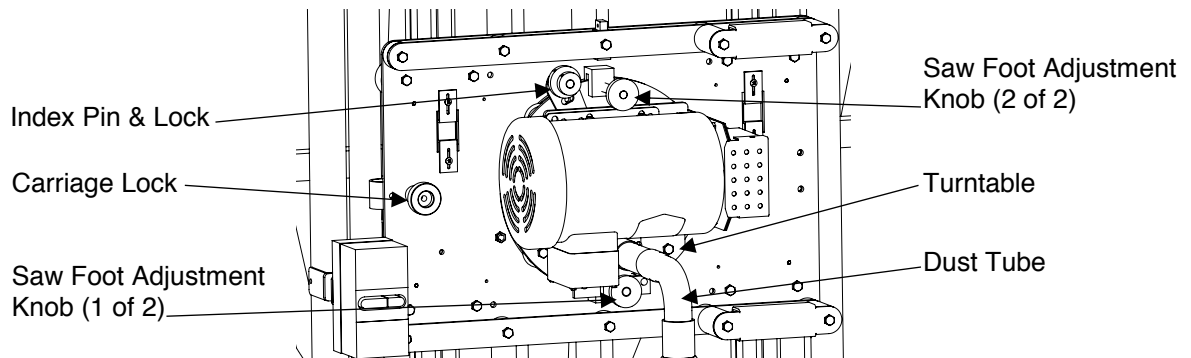

Figure 19: Changing a Saw Blade (7000 shown)

6. Rotate Turntable, if necessary, to the vertical cutting position.
7. Remove Dust Tube (Fig. 20) by pulling from saw base.

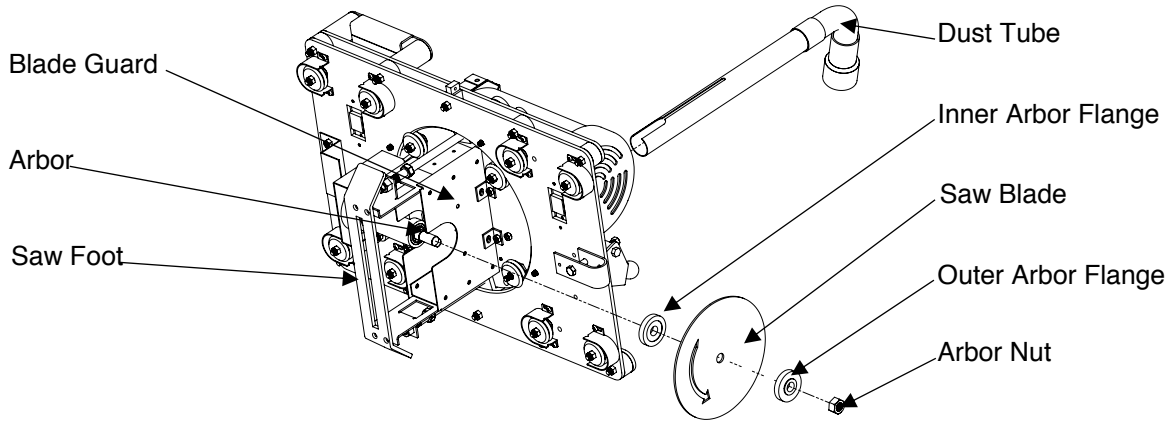

Figure 20: Changing a Saw Blade (Carriage viewed from underside)

8. Models without Scoring attachment:

Rotate both Saw Foot Adjustment Knobs to move Saw Foot to its lowest position (Fig. 21).

Models with Scoring attachment:

Rotate both Saw Foot Adjustment Knobs to move Saw Foot to its highest position (Fig. 21). Remove the two, brass, Saw Foot retaining bolts (Fig.24A) using a 1/2" wrench. Remove Saw Foot by lifting it up and off of the two Guide Pins (Fig. 24A).

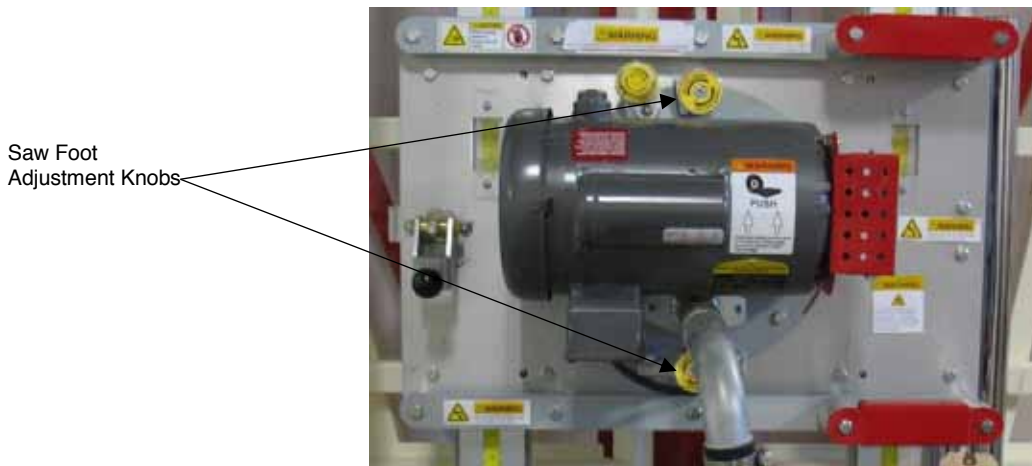

Figure 21: Saw Foot Adjustment Knobs (Crosscut Position)

9. Use the supplied wrenches to hold the arbor and loosen the arbor nut, from behind the machine. The slotted end of the wrench is designed to hold the arbor, on one end, while loosening the arbor nut, on the other end, with the box-end of the second wrench (Fig. 22 & 23). The two wrenches are interchangeable.



Figure 22: Slotted Arbor Wrench (holding)



Figure 23: Box-End Arbor Wrench (loosening)

10. While holding the arbor wrench steady, rotate the arbor nut Counter-Clockwise (downward) to loosen nut (Fig. 23), from back of machine.

11. Remove arbor nut and outer blade flange (Fig. 24).



Figure 24: Outer Blade Flange & Arbor Nut Removal

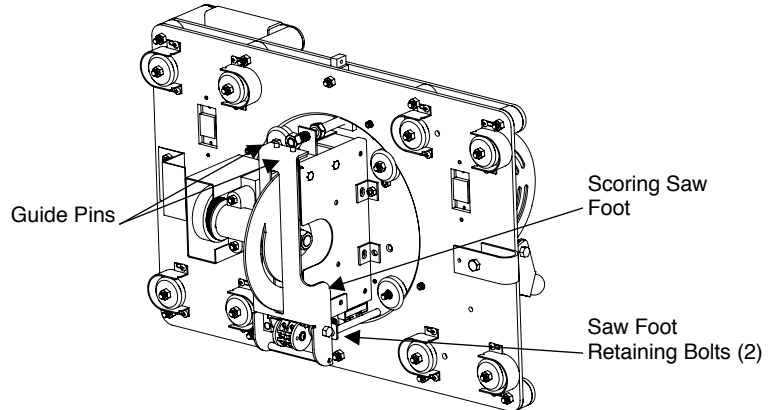

Figure 24A: Scoring Saw Foot components (underside)

12. Slide blade from arbor and remove through clearance between saw foot and saw frame (Fig. 25 & 26). Do not remove inner blade flange.



Figure 25: Blade Changing



Figure 26: Blade Changing

13. Install new blade, outer flange and arbor nut by reversing last procedure. Confirm the saw blade is oriented correctly. See label on side of blade guard (Fig. 26).
14. Securely tighten arbor nut, rotating clockwise (up) while holding arbor with slotted wrench (Fig. 22).
15. **Models without Scoring attachment:**
Adjust saw foot to provide slight pressure on material to be cut (Fig. 21).

NOTE: The saw foot should raise approximately 1/8" when it comes in contact with material being cut.

Models with Scoring attachment:

Reinstall Saw Foot by placing it over Guide Pins and seating it in place (Fig. 24A). Install the two, brass, Saw Foot retaining bolts (Fig. 24A) and tighten (do not overtighten). Adjust saw foot and Scoring Attachment for material thickness to be cut.

16. Reinstall dust tube, confirm slit in tube is centered on saw blade.
17. Slide frame filler back into place and secure (if so equipped).
18. Replace center metal filler section (if so equipped).
19. Loosen Carriage Lock and move Saw Carriage to top position.
20. Connect power and make a test cut.

NOTE: Crosscut and Rip Rulers may need to be adjusted after changing a saw blade.



To reduce the risk of injury, do not operate the tool without the saw foot blade guard and pulley guard in place.

Rulers

The 7000-7400 series of panel saws have two rip rulers mounted vertically on the guide tracks. One for measuring the distance from the material rollers (left ruler) to the (horizontal) saw blade and one for measuring the distance from the Mid-Way Fence (right, ruler) to the (horizontal) saw blade. Also included are a pair of crosscut rulers on both the Mid-Way Fence (if so equipped) and on the Quick Stop, one on each side of the saw. All rulers must be adjusted after installing a saw blade for the first time and possibly after changing a saw blade as each blade kerf may be different.

The crosscut (horizontal) rulers in the Mid-Way Fence and Quick Stop are located in a dovetailed groove. The rulers are held in place with magnets.

The two rip (vertical) measuring indicators (sight glass) can be adjusted up or down, and accurately read the distance from the underside of the saw blade (when in a horizontal cutting position) to the top of the material rollers (left ruler) or from the top of the Mid-Way Fence (right ruler) to the saw blade.

Adjusting the Crosscut Rulers:



Disconnect power to Saw before adjusting.

Observe appropriate Lockout/Tagout procedures to insure the tool cannot accidentally be powered.



Figure 27: Crosscut Ruler Adjustment

1. Confirm machine is turned OFF and saw blade installed.
2. Position Saw Carriage in Crosscut position, rotate if necessary (Pg. 22, Fig. 21).
3. Raise Saw Foot by turning both Saw Foot Lifting Knobs (Pg. 22, Fig. 21).
4. Place a Square (not included), graduated and at least 14" on one side on the material rollers.
5. Loosen the Carriage Lock and lower Saw Carriage until aligned with square.
6. Place one edge of the Square perpendicular against the tips of the saw blade. Place the other edge of the Square in front of the crosscut (horizontal) ruler. Slide the ruler (held with magnets) using your thumbs until the measurements are equal (Fig. 27).

NOTE: The crosscut rulers are held in place with magnets. Wrapping clear tape around ruler can prevent unauthorized adjustment.

7. Repeat above steps to adjust all crosscut rulers.
8. Make a test cut to confirm crosscut ruler is adjusted correctly. Readjust if necessary.

Adjusting the Rip Cut Rulers:



Disconnect power to Saw before adjusting.

Observe appropriate Lockout/Tagout procedures to insure the tool cannot accidentally be powered.

1. Confirm machine is turned OFF and saw blade installed.
2. Position Saw Carriage in Rip position, rotate Turntable if necessary (Fig. 28).
3. Raise Saw Foot by turning both Saw Foot Lifting Knobs (Pg. 22, Fig. 21).
4. Place a Square (not included), graduated and at least 14" on one side on the material rollers.
5. Loosen Carriage Lock and lower Saw Carriage to a location slightly above Square.
6. Carefully lower the Saw Carriage until the saw blade is lying flat (parallel) and lightly touching the top of the square. Tighten the carriage lock. Loosen the two screws holding the indicator to the saw carriage (Fig. 28).
7. Adjust the indicator (up or down) to match the dimension from the square. The ruler measurement should match the square measurement.
8. Tighten the screws holding the indicator and remove the square.



Figure 28: Rip Cut Ruler Adjustment (Rip Position, 7400 shown)

9. Repeat above steps to adjust all crosscut rulers.
10. Make a test cut to confirm ruler is adjusted correctly. Readjust if necessary.

Kerf Spreader

The Kerf Spreader is a feature that supports the top piece of stock when ripping (horizontal cut). It prevents the top piece from applying excessive pressure to the saw blade (preventing binding, marking and reducing the risk of kickback) and breaking of the material. The Kerf Spreader is located on the left side of the Saw Carriage (when facing saw) on a round tube. It is a steel support and is fully adjustable in height and depth (Fig. 29).

NOTE: The Kerf Spreader can be relocated to the right side of saw carriage for left-to-right ripping. Call SSM technical service for instructions (763-755-1600).

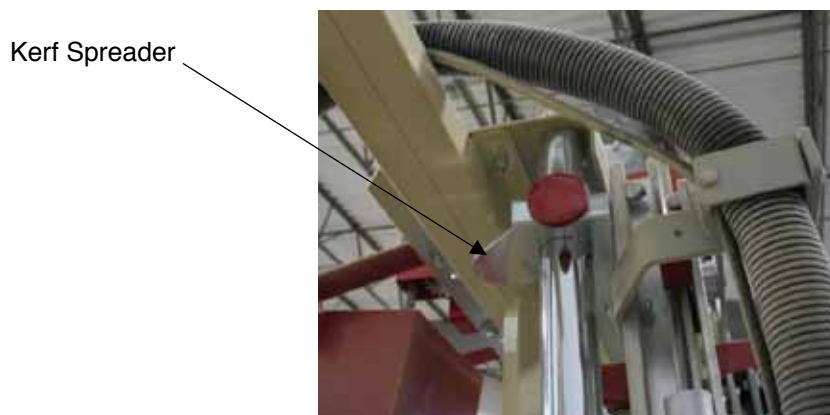

Figure 29: Kerf Spreader, storage (crosscut) position

Adjusting the Kerf Spreader:

NOTE: ALWAYS use Kerf Spreader when making Rip Cuts.

1. Position Saw Carriage for rip cut, rotate turntable if necessary.
2. Lock Saw Carriage in desired position for cut by tightening Carriage Lock.
3. Loosen the knob on the Kerf Spreader. This allows the Kerf Spreader to rotate and slide up and down.
4. With the knob loose, position the Kerf Spreader, at precisely the same height as the saw blade and rotate so Kerf Spreader will be aligned with saw blade and will support material (Fig. 30).



Figure 30: Kerf Spreader, in-line with saw blade, operational position

5. Tighten Knob of Kerf Spreader.
6. Make cut.
7. Reposition for other rip cuts or move to the top of the saw frame for storage if making cross cuts.

Hold Down Bar

The Hold Down Bar is a feature that clamps or “holds” material being cut against the saw frame. It is located on right side of the Saw Carriage and consists of a double tube that pivots. It applies pressure on the material being cut. The pressure can be adjusted by loosening or tightening the clamp at the bottom of the tube. This feature is very helpful when cutting very thin or flexible material (e.g. plastic sheets, plastic laminate, thin plywood, etc.) as it flattens and supports the material. It allows one person to effectively handle and support thin material. It is also very helpful when cutting several thin sheets at the same time as it flattens and supports all sheets in the same plane.

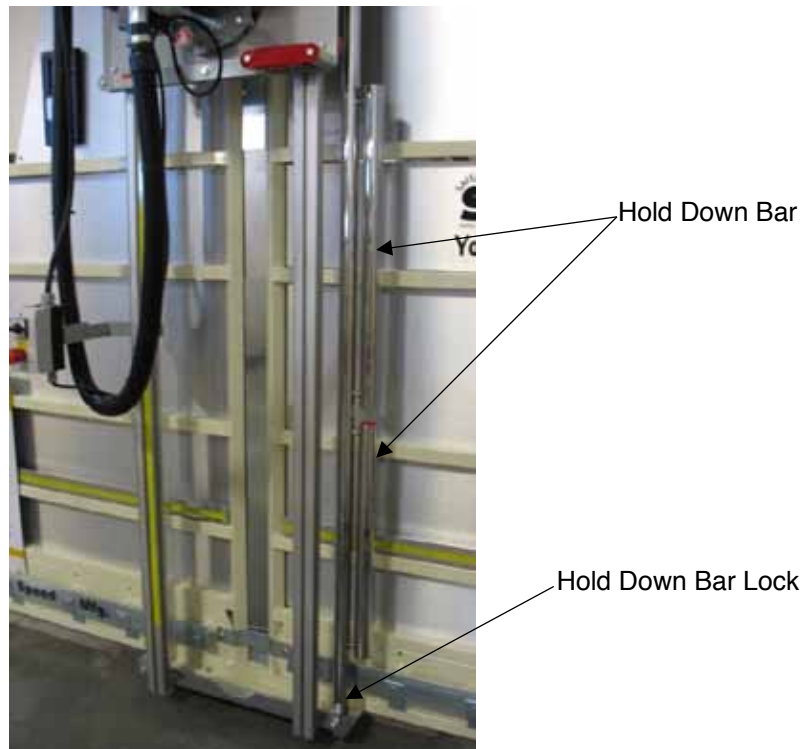

Figure 31: Hold Down Bar (7000HD shown)

Adjusting the Hold Down Bar:

1. Loosen Hold Down Bar Lock (bolt or knob, depending on model), located at the bottom of tube to the right of Saw Carriage.



Figure 32: Hold Down Bar Lock, 7000HD shown

2. Rotate Hold Down bar out and away from saw frame.
3. Place stock in position for cutting
4. Rotate Hold Down Bar against stock to be cut. When properly supported, tighten Hold Down Bar Lock (Fig. 32).

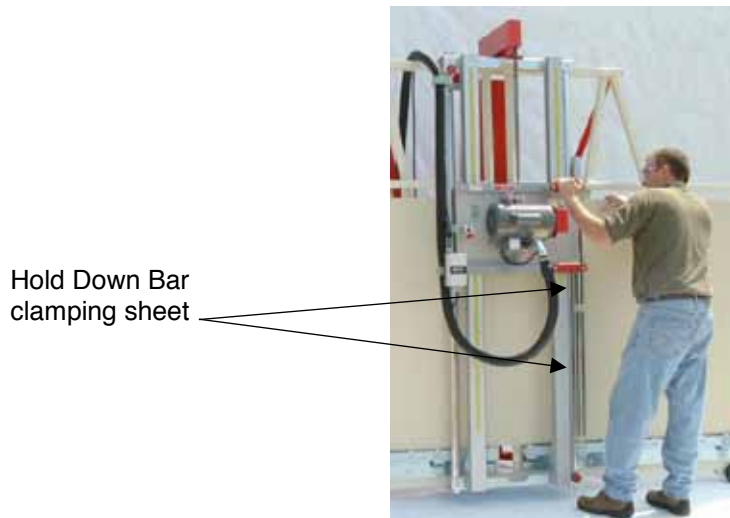

Figure 33: Hold Down Bar in use, 7400 shown

5. Cut stock. Adjust as necessary.

Dust Control

The included Dust Kit is a unique and patented dust control system. It features a telescoping tube which moves down through the saw carriage and is protected by the adjustable Saw Foot. The telescoping tube partially encircles the saw blade and draws dust off the saw blade as it leaves the kerf line.

To minimize maintenance and protect the operator's health this system should be used. A proper vacuum source is required and should provide a minimum of 100 CFM, 90" – 110" of static pressure and a 1-1.2" I.D. hose connection. Some in-house dust collection systems will work, however one of the best options is a high quality, industrial shop vac. Safety Speed Manufacturing offers Industrial vacuums (Pg. 57), call for detailed information (763-755-1600) or visit safetyspeed.com

Knife Scoring System (optional w/7400 models, installed at SSM)

The Knife Scoring System provides two crisp, clean score marks on the surface of the material being cut, in line with the kerf of the saw blade. This system dramatically reduces if not eliminates the most common reason for tear-out. The knives are factory set to score .009" deep. Call SSM technical service for replacement scoring knives (763)-755-1600.

NOTE: Some inferior coated particle board panels have a substrate that when cut, even with scoring knives, will pull large particles to the surface that can chip the cut line beyond the edge of scoring.

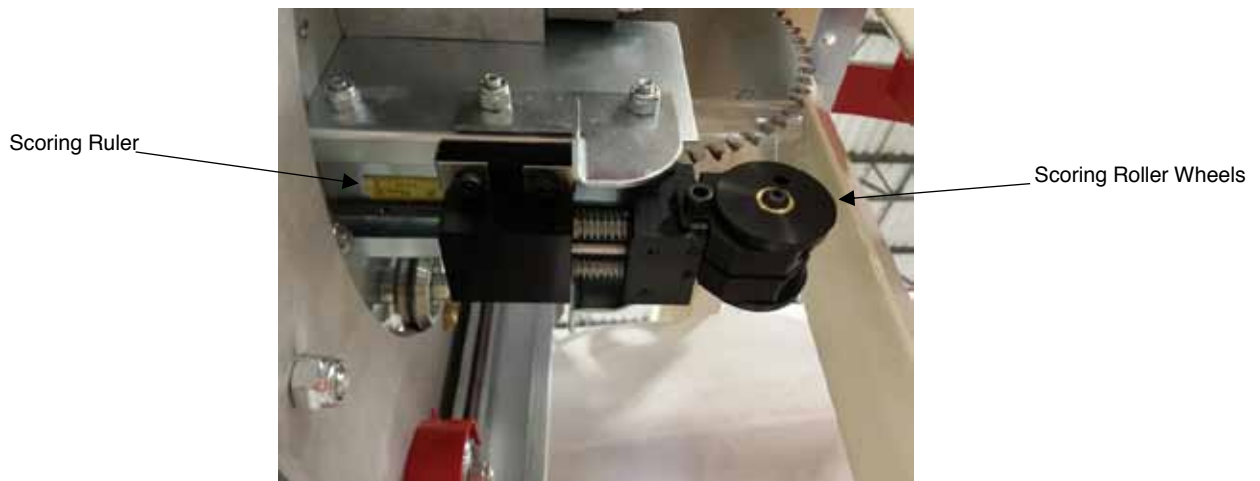

Figure 34: Scoring Attachment 7400

The width of the score marks is adjustable, to accommodate a variety of saw blade kerfs (widths). The scoring knives have four cutting edges, which can be rotated when dull and replaced when all edges are worn.

Knife Adjustment:

The Scoring Knives can be adjusted side-to-side to best match the kerf of the saw blade. Most conditions and materials respond well to the score mark being approximately .002" wider than the saw kerf. The Scoring System can be adjusted UP & DOWN to compensate for various material thicknesses or UP and disconnected when scoring is not desired.

NOTE: The Scoring Roller Wheels (Fig. 34) should raise approximately 1/8" when contacting material to be cut.

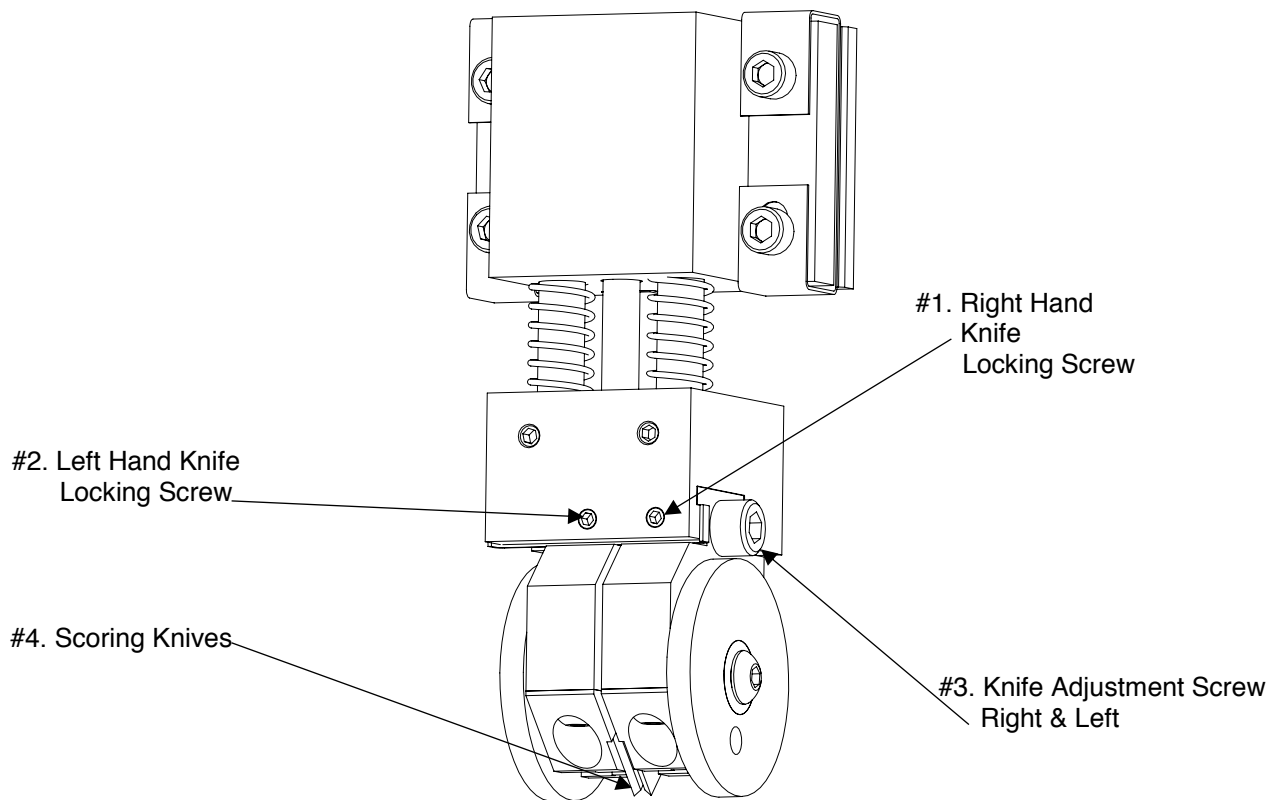

Figure 35: Scoring System

To adjust the right side (hand) knife:

1. Loosen set screw #1, Fig. 35.
2. A. Rotate set screw #3 clockwise to move right knife closer to kerf.
B. Rotate set screw #3 counter-clockwise to move right knife away from kerf.
3. Tighten set screw #1.
4. Make test cut, repeat process if necessary.

To adjust the left side (hand) knife:

1. Loosen set screw #2, Fig. 35.
2. A. Rotate set screw #3 clockwise to move left knife closer to kerf.
B. Rotate set screw #3 counter-clockwise to move left knife away from kerf.
3. Tighten set screw #2.
4. Make test cut, repeat process if necessary.

To adjust both the left and right side (hand) knife:

NOTE: This procedure does not change distance between knives.

NOTE: DO NOT loosen or adjust #3, Fig. 35 for this procedure.

1. Loosen both set screws #1 & #2, Fig. 35.
2. Slide both knife holders in the correct direction.
3. Tighten both set screws #1 & #2.
4. Make test cut, repeat process if necessary.

Disengaging Scoring System:

To disengage Scoring System:

1. Make note of measurement on Scoring Ruler (Fig. 34) for fast repositioning of Scoring System when cutting equal thickness material. Loosen the four system locking screws #5, Fig. 36.

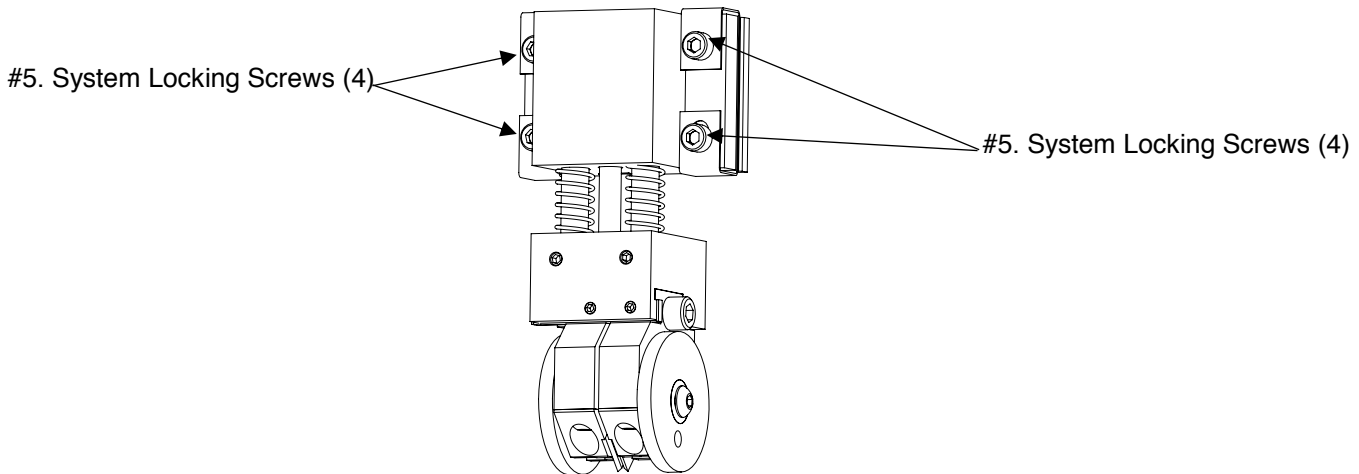

Figure 36: Disengage Scoring

2. Slide entire Scoring System "up" to disengage from material being cut. Confirm stock will not contact knives.
3. Tighten all four System Locking Screws, #5, Fig. 36.

Engaging Scoring System:

NOTE: The Scoring Guide Wheels should raise approximately 1/8" when contacting material to be cut.

To engage Scoring System:

1. Loosen the four system locking screws #5, Fig. 37

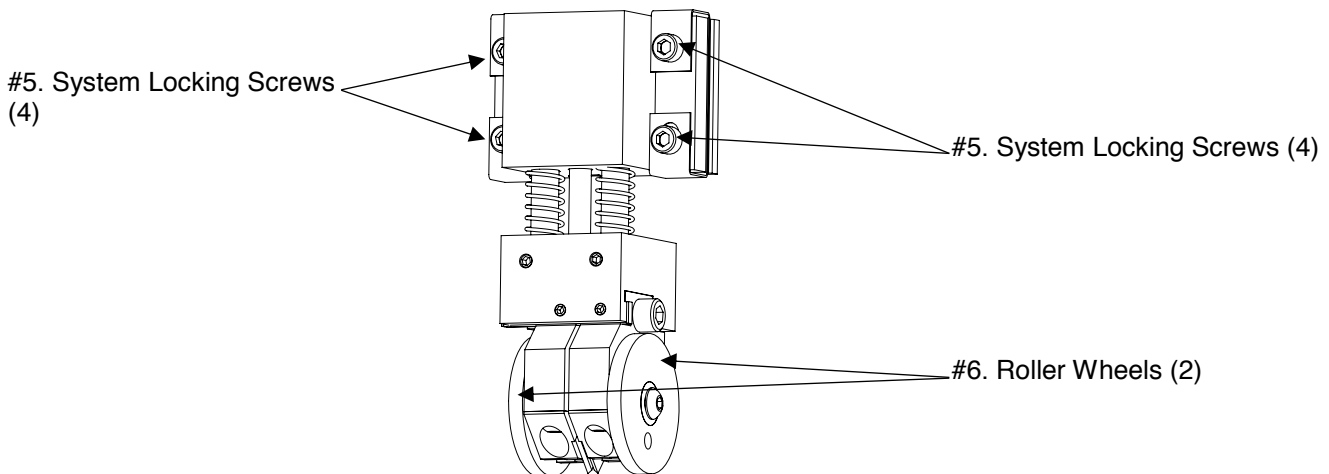

Figure 37: Engage Scoring

2. Slide entire Scoring System down to engage material being cut. The Roller Wheels should raise approximately 1/8" when contacting the material to be cut. Note the measurement on the Scoring Ruler (Pg. 29, Fig. 34) for fast positioning of the Scoring System when the same material thickness is cut in the future. Fine tuning the actual position of the Scoring System may be necessary for specific applications.

NOTE: The Roller Wheels (Fig. 37, # 6) should raise approximately 1/8" when engaging material.

3. Tighten all four System Locking Screws, #5, Fig. 37.

Rotating/Replacing Scoring Knives:

NOTE: Call Safety Speed Mfg. for replacement carbide scoring knives, (763-755-1600). It is a good idea to have extra knives on hand to prevent unnecessary downtime.

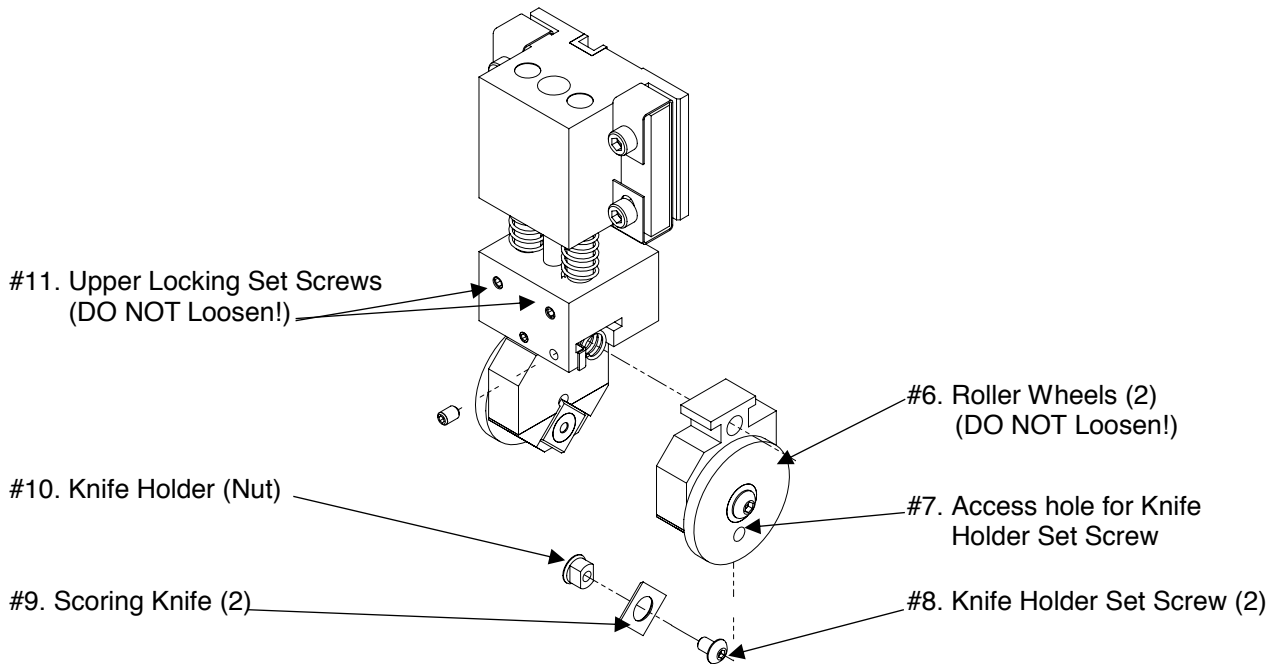

Figure 38: Scoring Knife Rotating/Replacing

1. DO NOT remove Roller Wheels (#6, Fig. 38).
2. Loosen both Right and Left Hand Knife Locking screws (#1 & 2, Fig. 35) and separate both knives.
3. Align Access Hole in Roller Wheel (#7, Fig. 38) with Set Screw for Knife.
4. Using 3/32" hex wrench, carefully loosen Knife Set Screw.
5. Raise Knife Holder & Nut (#10, Fig. 38) and rotate (or replace) Knife.
6. Confirm Knife Holder & Nut are in proper position and not binding and tighten Set Screw for Knife.
7. Repeat this procedure to rotate or change the knife on the opposite side.

NOTE: DO NOT loosen or remove #11, Upper Locking set screws or #6 Roller Wheel (Fig. 38).

Scoring System Maintenance:

Regular maintenance will keep the Scoring System working trouble free and extend the life of all the components.

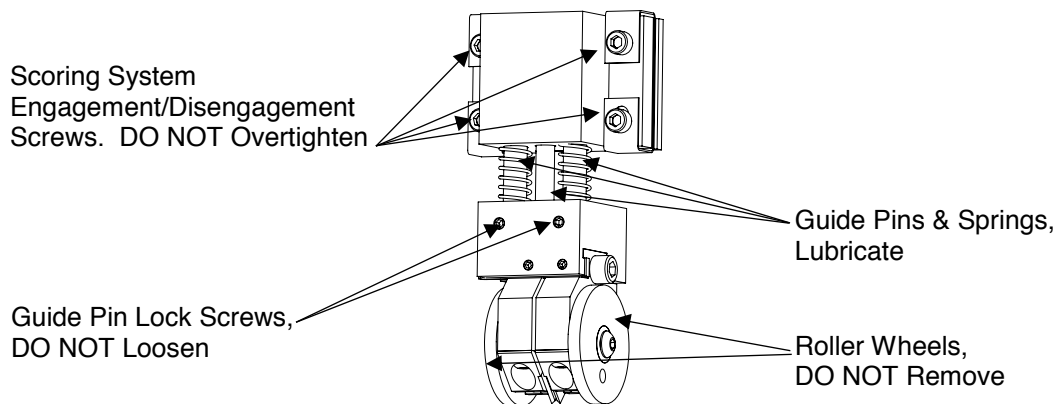

Figure 39: Scoring System Maintenance

1. Blow the Scoring System with compressed air before rotating or changing knives.



Use proper safety equipment and procedures when using compressed air. Use safety glasses, face shields, gloves and protective clothing. Make certain no bystanders will be in area.

2. Lubricate guide pins with lightweight machine oil or silicone spray as necessary (Fig. 39).
3. Keep Scoring system clean by vacuuming and brushing on a regular basis.

OPERATION



The following are suggestions that give a general idea of how a panel saw is intended to be operated. No instructions can replace common sense and experience. Be sure all operators have enough time and material to become familiar with the operating characteristics of this tool, and have FULLY READ AND UNDERSTOOD all operating and safety instructions.

Capacities of the Tool

Small Work pieces



Do not cut pieces that are so small that your hand must be behind the saw carriage to hold the piece in place. Use a tool better suited to these applications, such as a table saw, radial arm saw, chop saw, band saw, router table, etc.

Work piece Height (Crosscutting capacities)

Maximum crosscutting of a work piece, 7000 or 7400 series:

- 64" (1625mm)

Crosscutting

Crosscutting (vertical cuts) requires the work piece to be supported on at least two rollers (Pg. 40, Fig. 45) for safe operation and accurate cutting. Using the Mid-Way Fence, the work piece must extend at least 4" (100mm) beyond the carriage on both sides (Pg. 39, Fig. 43).

Do not crosscut work pieces that extend more than 5 feet (1520mm) beyond the outermost roller. To increase available capacity for these larger panels, SSM recommends using the optional Frame Extensions (Pg. 50, Fig. 53).

Work Piece Thickness Capacities

Maximum thickness of a work piece to be cut with 7000HD:

1-3/4" (45mm)

Maximum thickness of a work piece to be cut with 7000 series (non-HD):

2" (50mm)

Maximum thickness of a work piece to be cut with 7400 series:

2-1/8" (55mm)

Rip Cutting Capacities



The **minimum length** recommended for rip (horizontal) cuts is **2-1/2 feet** (760mm), so the work piece will be supported on at least four rollers. Pieces shorter than 4 feet (1220mm) can be rotated 90° and be crosscut. This size limitation also applies when using the optional Midway Fence (Pg. 43, Fig. 48).

There is no limit to the length of stock that can be rip cut. However, it is critical the stock is properly supported at all times. For regular rip cutting of long pieces, SSM recommends using optional Frame Extensions.

Selecting a Saw Blade

The saw blade must be carefully matched to the materials being cut. Improper blade selection can result in reduced tool life, inaccurate and poor quality cuts, and safety risks.

NOTE: The following table lists some recommended blades for certain applications.

If in doubt, consult with your machinery dealer, or with our customer service department (763-755-1600), to determine the best blade for your cutting needs.

NOTE: It is a good idea to have replacement blades on hand to prevent unnecessary downtime.

Table III: Recommended SSM Blades for Certain Applications

Material	8200HG	840ATB	860ATBL	860ATB	864NRATB	860NRTCG	860TCG	860TCGS	880ATBL	880TCGL
Aluminum composite						X	X	X		
Aluminum plate						X				
Chipboard		X	X	X			X		X	
Double-face panels			X		X	X			X	
Duraply							X			X
Gatorfoam								X	X	
Hardwood		X	X	X					X	
Laminated panels		X	X						X	
Masonite		X	X				X		X	
Melamine					X	X				X
Particle board		X	X				X	X	X	
Plexiglas up to 1/2"							X	X		
Plywood		X	X	X				X	X	
Polycarb. (Lexan)	X							X		
Polyester					X	X				X
Printed grain lamin.					X					X
Solid wood		X	X	X				X	X	
Veneer			X		X				X	
Vinyl					X	X			X	

Always keep blades clean and sharp for the best performance. A dull or dirty blade can bind and pinch, resulting in kickback and poor quality cuts. If in doubt, replace it with a new/sharp blade.

The blade diameters specified for SSM panel saws are 8" (200mm), with an arbor of 5/8" (16mm). Minimum blade kerf for the saw blade is .10" (2.5mm).



Kerf Spreader thickness is .085" (1.98mm), blades thinner than this kerf should NOT be used!



Only blades made in conformity to BS EN 847-1:2013 should be used on SSM machines.

Basic Operating Controls and Functions

Refer to figure 40 for the location of basic operator controls.



Figure 40: Basic Operating Controls and Components, 7400 shown

Starting and Stopping the Motors:

Start the saw motor by pushing the black button ON or twisting the black knob ON (depending on model).

Stop the saw motor by pressing the red button OFF or twisting the black knob OFF (depending on model).

NOTE: Some models are equipped with an Emergency Red STOP button. Use ONLY for Emergency Stopping.

NOTE: 7000HD requires authorized key pad entry to start saw.



Unplug Saw before adjusting.

Observe appropriate Lockout/Tagout procedures to insure the tool cannot accidentally be powered.

Rotating the Turntable on the Saw Carriage:

1. Loosen the Lock Knob (counter-clockwise) on the Indexing Pin (Fig. 40).
2. Loosen the Index Pin Knob (counter-clockwise) high enough for Indexing Pin to clear alignment hole (brass sleeve) in mounting plate (Fig. 40).
3. Rotate Saw on Turntable with Index Pin centered over alignment hole (brass sleeve) in carriage.
4. Tighten Index Pin, but do not overtighten as this can damage index pin or alignment hole (brass sleeve) in the carriage.
5. Tighten (clockwise) Lock Knob on Index Pin.



Index Pin



Index Pin Lock Knob

Moving the Carriage Up or Down

Use either or both of the two handles attached to the right side of Saw Carriage (Fig. 41 & 42).

Locking the Carriage

Lock the saw carriage by tightening the Carriage Lock, on the left side of Saw Carriage (Fig. 41 & 42).

- 7000 Series: Tighten by rotating the Carriage Lock knob clockwise.

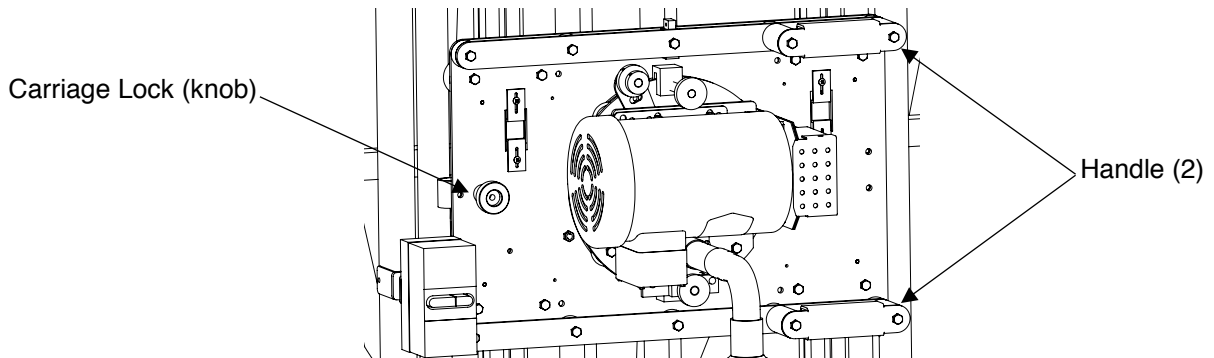

Figure 41: Carriage Lock, 7000

- 7400 Series: Tighten by pivoting the Carriage Lock handle "down" toward carriage.

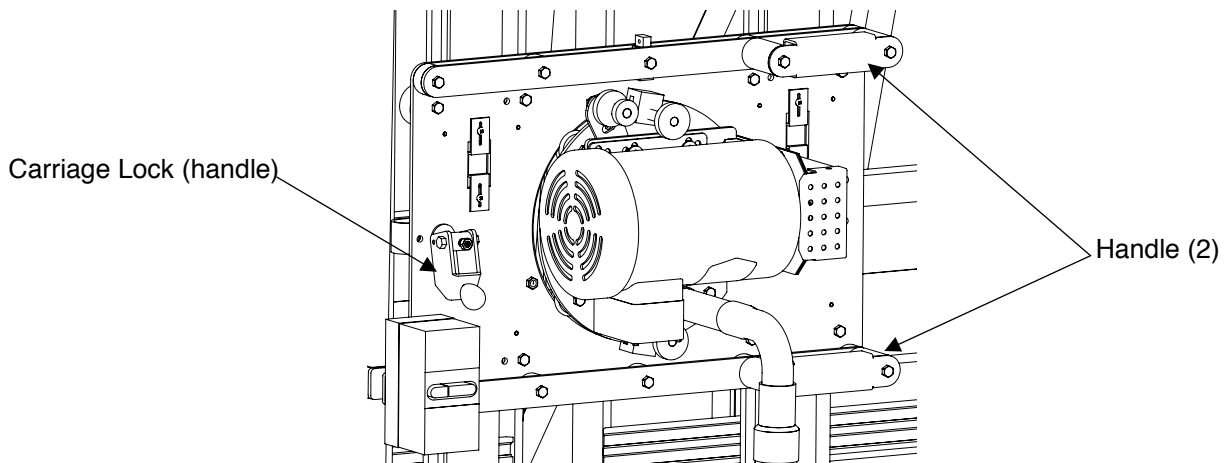

Figure 42: Carriage Lock, 7400

General Operating Tips

- For smooth, clean, chip-free cuts, you **must** use industrial carbide saw blades and bits that are **sharp**. Dull or improperly sharpened blades will cause chipping, unclean cuts, chatter, and motor overloading. **If you are not sure that a blade is sharp, replace it with a new/sharp one.**

- When feeding material through the tool horizontally, or moving the carriage over the material vertically, **do it slowly, smoothly, in the direction of the arrows on the carriage labels and (whenever possible) without stopping.** Overfeeding results in poor-quality cuts, shortened blade life and motor overloading.
- Be careful when setting stock onto the material rollers. **Do not drop material onto the rollers** or damage to the rollers may result.
- For best results when sawing, place the work piece onto the tool with its backside facing you. This provides the smoothest possible cut on the face side of the panel.
- Always confirm Saw Foot or Guide Wheels are lightly pressing on stock being cut. This improves accuracy and reduces chatter.
- Panels being cut horizontally or vertically must always be fed against the rotation of the saw blade.
- Vertical panel saws are intended for cutting **large** panels down to size. As the overall panel size becomes smaller and smaller consider using the “**Midway Fence**” (Pg. 39 & 52) or other types of sawing tools as they become more convenient and safer to use when cutting small stock.
- Refer to the Maintenance section for regular maintenance procedures.

Operating Procedure: Crosscutting

A crosscut is a vertical cut that must always be done from the top to the bottom of a work piece (Fig. 43). (See also “**General Operating Tips**” and “**Capacities of the Tool**”.)

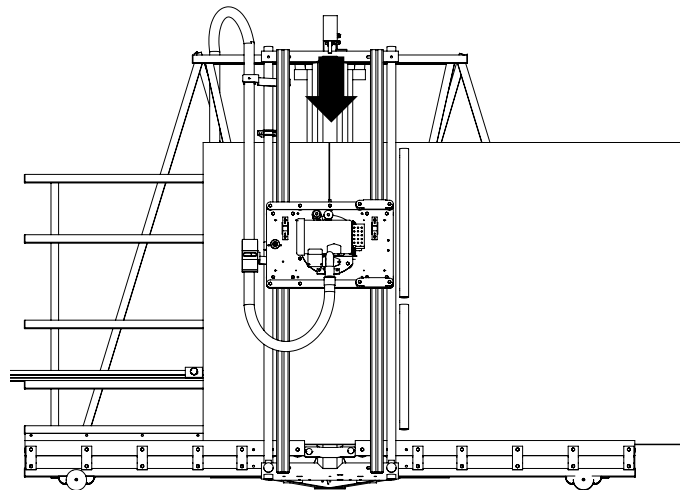

Figure 43: Crosscutting (material supported on minimum of two material rollers)



To reduce the risk of injury, do not place your hands on or under the saw carriage or in the path of the saw blade.

1. Position the saw motor in the crosscutting position with the blade oriented vertically. See “**Rotating the Turntable**”.
2. Loosen the Carriage Lock and move the Saw Carriage to the top of the guide tracks.



Figure 44: Crosscut motor position (7400 shown)

3. Place the work piece on top of the material rollers. Be careful not to drop the material on the rollers.
4. Slide the work piece to the desired position, using the crosscut rulers or optional gauging systems (Stop Bar or Quick Stop) as measures.
5. Make certain that the work piece is adequately supported and stable in the machine. Refer also to “**Capacities of the Tool**”.



6. **Do not hold the work piece so that your hand is anywhere behind the carriage or guide tracks or in the path of the saw blade!**
7. Adjust the position of the spring-loaded Saw Foot by rotating each of the two Saw Foot Lifting Knobs. Position the Saw Foot so it raises slightly and presses lightly on the face of the stock being cut. This reduces chatter and increases accuracy of the cut.

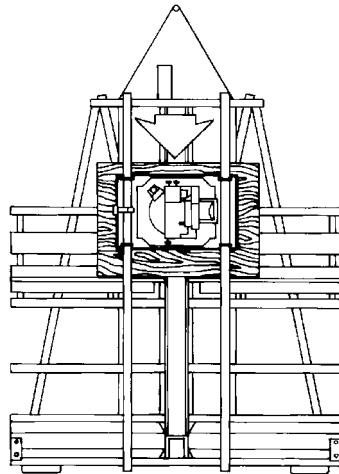

Figure 45: Crosscutting using Midway Fence (material must extend beyond saw carriage at least 4” (100mm))

8. Start the motor (see “**Starting and Stopping the Motor**”), and allow it to reach full speed before beginning the cut.
9. When the motor has reached full speed, slowly and smoothly pull the carriage down so the blade runs through the work piece. **Keep one hand on a carriage handle at all times and the other hand clear of saw carriage.** Be careful not to force the saw through the work piece, to avoid binding.

CAUTION

If the blade binds in the work piece, or the work piece shifts during the cut, stop the motor, carefully move the carriage to the top of the guides, restart the motor, and begin the cut again.

- 10. Support and remove the cut-off piece as the saw completes its cut.
- 11. Once the cut is complete, turn OFF the motor and wait for the blade to come to a full stop. Move the work piece away from the blade. Return the carriage to the top of the guide tracks and tighten the carriage lock.

NOTE: A coasting saw blade could mar the edge of a freshly cut work piece.

Operating Procedure: Rip cutting

A rip cut is a horizontal cut typically accomplished from right-to-left (recommended) (Fig. 46). Rip cuts **must always** be done by moving the work piece in the direction of the arrow on the saw carriage (motor). (See also “General Operating Tips” and “Capacities of the Tool.”)

NOTE: Rip cutting from left-to-right is possible by moving the Kerf Spreader to the right side of guide tracks (and the Hold Down Bar to the left). Call SSM Technical Service for these instructions, (763)-755-1600.

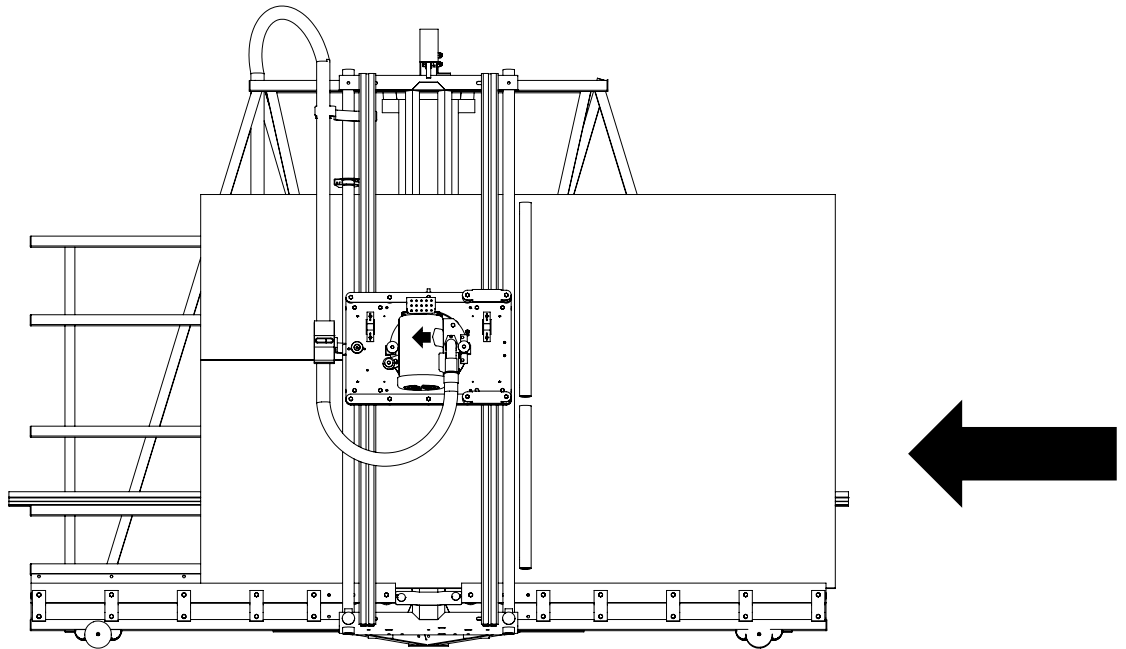

Figure 46: Rip Cutting Saw Motor Position and feed direction

WARNING

To reduce the risk of injury, ripping must always be done with the direction of the arrow on the saw.



1. Before starting, confirm there is enough space on both sides of the saw to completely load the work piece on the saw frame, move it past the saw, and completely off-load it.
2. Select the ripping direction, from right or from left, based on preference and location of Kerf Spreader.
Rotate the turntable to the ripping position as shown on Pg. 40, Fig. 46 (see “**Rotating the Turntable**”). The rip measurement is set at the factory for cutting right to left. The measurement indicator will need to be adjusted for left to right as well as exchanging (from side-to-side) the Kerf Spreader and Hold Down Bars. Call SSM Technical Service (**763-755-1600**) for instructions for changing the Kerf Spreader and Hold Down Bars from side-to-side.
3. Select the height of the saw blade above the material rollers. Raise or lower the saw carriage until the height index indicator is aligned with the corresponding dimension on the vertically mounted ruler. Lock the carriage securely to the guide track in this position by tightening the Carriage Lock.
4. Adjust the position of the spring-loaded Saw Foot by rotating each of the two Saw Foot Lifting Knobs. Position the Saw Foot so it raises slightly and presses lightly on the face of the stock being cut. This reduces chatter and increases accuracy of the cut.
5. Position the Kerf Spreader (see “**Adjusting the Kerf Spreader**”) at the same height as the saw blade (Fig. 47). Rotate so Kerf Spreader will be aligned with saw blade and will support material and lock in place.



The Kerf Spreader must always be positioned behind the saw blade when Rip Cutting!



Figure 47: Kerf Spreader, in-line with saw blade

6. Start the motor (see “**Starting and Stopping the Motor**”) and allow it to reach full speed before beginning the cut.



Figure 48: Rip cutting motor position (7400 shown)

7. Position the material on the side of the machine indicated by the arrows on the carriage that show direction of cut. Place the work piece on top of the material rollers. Be careful not to drop the material onto the rollers.
8. When the motor has reached full speed, slowly and smoothly push the work piece through the saw, in the direction of the feed arrow on the saw. Be careful not to force the work piece through the saw, to avoid binding.



Avoid placing your hands, clothing, or body parts under the saw carriage or in the cutting path of the saw blade. Do not look directly down the line of cut because dust and debris are generated during this operation.



If the saw blade binds in the work piece, or the work piece shifts during the cut, stop the saw motor, carefully back the work piece out of the saw, reposition the work piece, restart the motor, and begin the cut again.

9. As the work piece passes across the saw, move to the other side and complete the cut by pulling the work piece past the saw blade. Support the upper piece to keep it from pinching the blade by positioning the Kerf Spreader at the same height as the saw blade.
10. Once the cut is complete, turn off the motor and wait for the blade to come to a full stop. Remove the work pieces from the machine.
11. Rotate the turntable back to the vertical position and return the carriage to the top of the guides. Lock the carriage in this position.

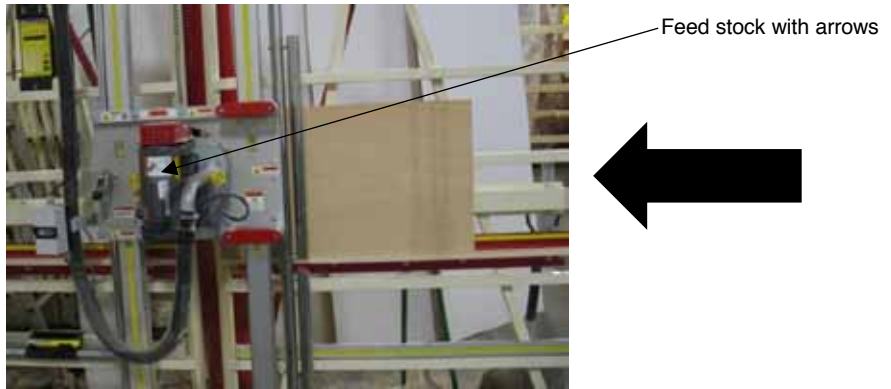

Figure 49: Rip cutting, from the Right, using optional Midway Fence



Figure 50: Saw Foot (guard & chatter preventer) in position for rip cutting (7000 shown, top-down view)

MAINTENANCE



To reduce the risk of injury, always unplug the tool before doing any maintenance. Never disassemble the tool or try to do any rewiring to its electrical system. Contact a qualified electrician for electrical repairs. Always follow Lockout/Tagout procedures when servicing electrical equipment.

General Maintenance

Keep the tool in good repair by adopting a regular maintenance program.

Each day; examine the general condition of the tool, and inspect the guards, switches and power cord for damage. Clean bearing with a rag or clean paint brush. Check for loose screws, misalignment, binding of moving parts, improper mounting, broken parts, and any other condition that may affect safe operation. If abnormal noise or vibration occurs, turn the tool OFF immediately and have the problem corrected before further use. Do not use a damaged tool. Tag damaged tools “**DO NOT USE**” until repaired (see “**Repairs**”).

Monthly; Sharpen or replace saw blade. This may necessary more often depending on use and conditions. Check ruler measurements and calibrate if necessary.

Cleaning



Unplug Saw before cleaning.

Observe appropriate Lockout/Tagout procedures to insure the tool cannot accidentally be powered.

Daily, clean/vacuum all dust and debris from the vents in the motor housing, carriage and around saw.

Keep the handles clean, dry and free from oil and grease.

Use only mild soap and a damp cloth to clean the tool, because certain cleaning agents and solvents are harmful to plastics and other insulated parts. Some of these harmful agents include: gasoline, turpentine, lacquer thinner, paint thinner, chlorinated cleaning solvents, ammonia, and household detergents containing ammonia. Never use flammable or combustible solvents around tools.



To reduce the risk of injury, electric shock, and damage to the tool, never immerse the saw in liquid or allow a liquid to flow inside it.

Maintaining the Motor



Unplug Saw before inspecting.

Observe appropriate Lockout/Tagout procedures to insure the tool cannot accidentally be powered.

Under normal conditions.

Every six months:

- Inspect belts and pulleys, and replace as necessary.
- Mechanically inspect and clean the gears, arbor, bearings, housing, etc.
- Inspect the switch, cord, armature, etc. for cracks or other issues.
- Test to assure proper mechanical and electrical operation.

Maintaining the Guide Tracks

The saw carriage should move smoothly up and down the guide tracks. However, if the guide tracks become caked with dust or debris, the carriage may get stuck or it may not slide smoothly. Periodically clean the guide tracks with a damp cloth, following the directions under “**Cleaning**” above.

SERVICE

Repairs

If your tool is damaged, call your purchasing dealer or Safety Speed at **(763) 755-1600** for technical advice or for the name of a dealer near you who can service your machine.

NOTE: To save time have your **Model Number** and **Serial Number** available when calling for parts and accessories. See inside cover of this manual or model/serial label on top/left of saw frame (**Pg. 2, Fig. 1**).

Alignment

The 7000 Series panel saws are aligned at the factory to a tolerance of:

- $\pm 1/64"$ (.4mm)

The 7400 Series panel saws are aligned at the factory to a tolerance of:

- ± 0.005 (.13mm)

Realignment is only required if the saw is mishandled or abused, or if the motor or a material roller is replaced.

Alignment consists of these steps done in the following order (explained in detail below):

1. Adjust the saw blade so it is parallel with the guide tracks.
2. Adjust the guide tracks so they are perpendicular to the material rollers.
3. Align the material rollers. Call SSM Technical Service for instructions **(763)-755-1600**.

Constructing an Alignment Tool

For maximum accuracy, construct a test square to check the full movement of the saw.

See figure 51. Construct the square using a 6-ft (1830mm) metal ruler and two 4-ft (1220mm) metal rulers. (Using the 3' (915mm), 4' (1220mm), and 5' (1520mm) measurements assures squareness.) Drill holes and attach the rulers with pop rivets or small nuts and bolts.

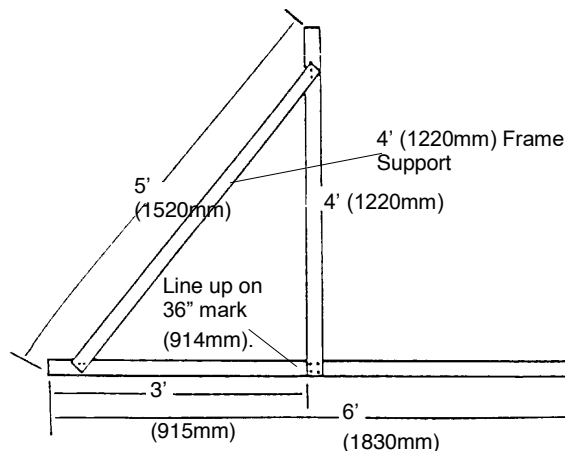

Figure 51: Field Alignment Tool

Use the 6-ft (1830mm) ruler to check rollers for square. Use the 4-ft (1220mm) ruler to check guide tubes (or rails) for square. The tool also can be used as a giant square for layouts.

Step 1: Adjust the Blade Parallel to the Guides

The saw blade must move parallel to the guide tracks, or tail burning may occur and the kerf will be wider than the set of the saw blade. Make the following adjustment only if the blade appears to be out of alignment or if the arbor was replaced.

To check the saw blade parallelism:

1. If the blade “heels”, or leaves burn marks on the cut, position the saw carriage for a crosscut and make a sample cut. Check both sides of the cut to determine which side of the saw blade is causing the problem (you will need this information for adjusting the saw blade).

To adjust the saw blade parallelism:



Unplug tool before making adjustments.

Observe appropriate Lockout/Tagout procedures to insure the tool cannot accidentally be powered.

1. Position the Adjustment Tool on the material rollers. Lower the saw carriage so the Adjustment Tool overhangs the saw blade.
2. Place the Adjustment Tool against the saw blade. The entire face of the saw blade should contact the Adjustment Tool. If it does not, then the saw blade is not parallel to the guide tracks. To adjust:
 - a. Loosen (but do not remove) the hex-nut and bolt nearest the Indexing Pin (Fig. 52).
 - b. If burn marks appear on the **left side** of the work piece, rotate the saw slightly clockwise until the entire face of the blade contacts the Adjustment Tool.
 - c. If burn marks appear on the **right side** of the work piece, rotate the saw slightly counterclockwise until the entire face of the blade contacts the Adjustment Tool.

Make only a slight adjustment at a time.

3. Securely tighten the hex nut.
4. Make a sample cut and readjust if necessary.

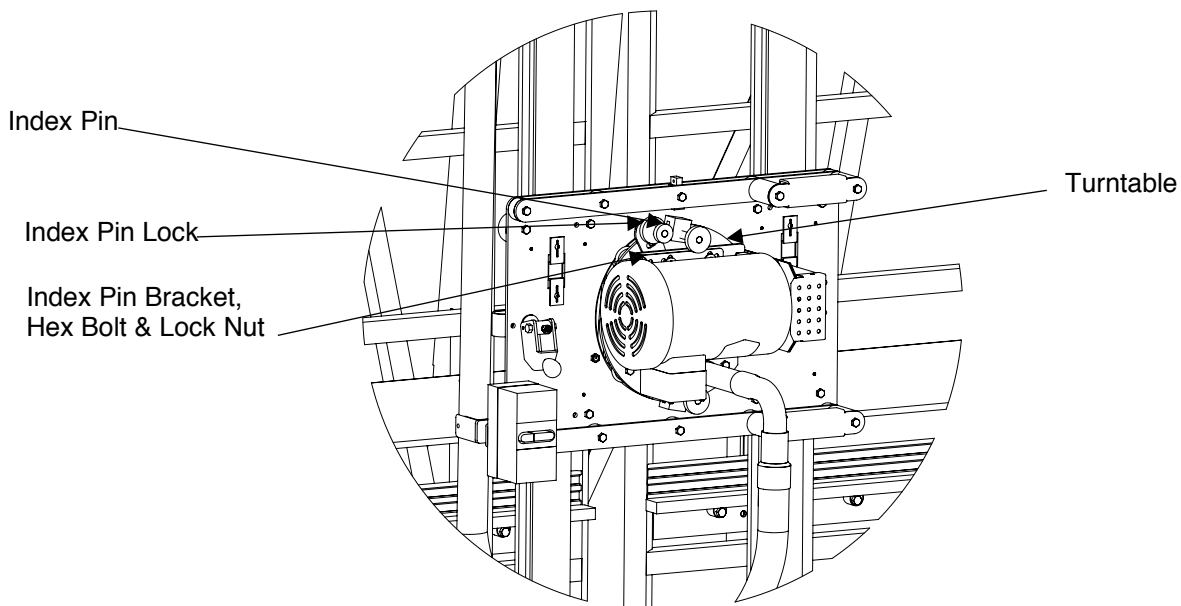

Figure 52: Adjusting Blade Perpendicularity (7400 shown)

Step 2: Align the Guide Tracks



Unplug tool before making adjustments.

Observe appropriate Lockout/Tagout procedures to insure the tool cannot accidentally be powered.

If the tool does not cut at 90°, the two guides may not be perpendicular to the rollers or fence.

To check the guide track alignment:

1. Mark a tooth on the saw blade to use as a reference. If you are using a high-speed steel blade, mark a tooth that points toward the edge of the **Alignment Tool** (Pg. 45, Fig. 51, described earlier).
2. Clamp the Alignment Tool to the roller assembly.
3. Pull the carriage down slowly until the marked reference tooth just touches the vertical edge of the Alignment Tool. Continue to pull the carriage down: if the blade does not contact the square, or if the blade binds on the square, the guide tracks are not aligned.

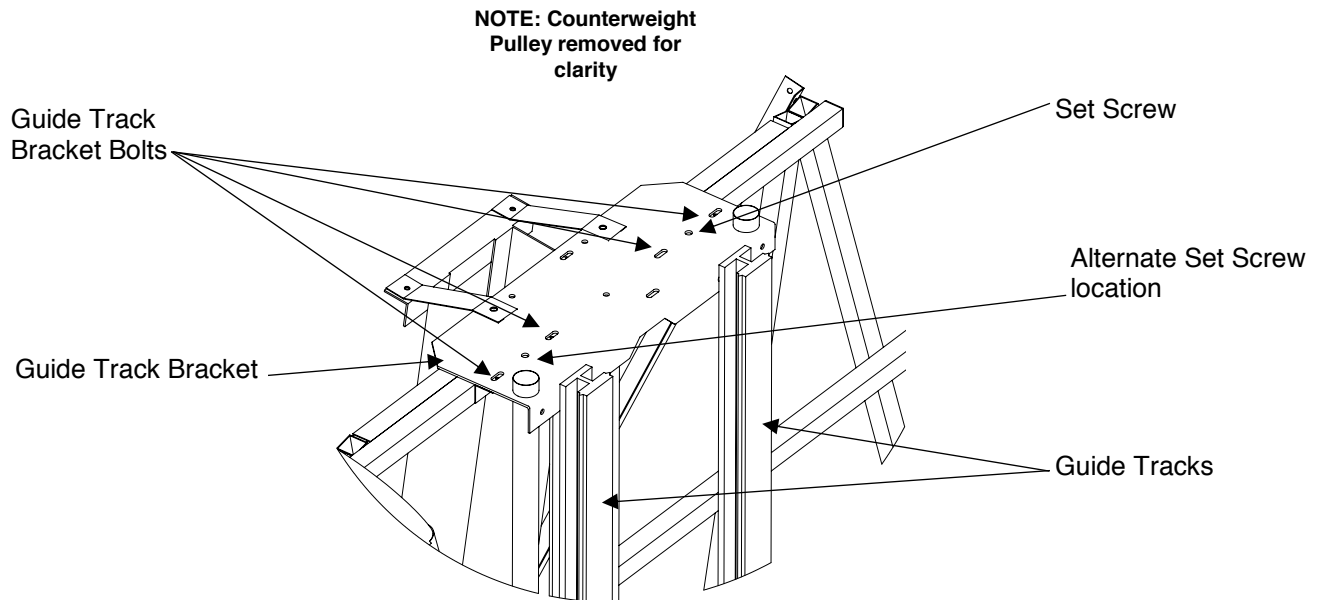

To align the Guide Tracks:

1. Remove set screw, which indicates original position of guide tracks (Fig. 53). Loosen the four guide track bracket nuts and bolts (Fig. 53), but **DO NOT** remove the bolts or the bracket. Using a dead blow mallet, strike the bracket on the side and in the direction you wish the guide tracks to go.

NOTE: Do not strike the Guide Tracks.

NOTE: Only adjust the top of the Guide Tracks

2. Recheck that guide tracks are square to rollers, using the procedure outlined previously. Readjust if necessary.
3. Securely retighten the guide track bracket nuts.
4. Install and securely tighten the set screw.

NOTE: If the set screw pulls the guide tracks out of alignment when reinstalling, use hole (alternate set screw location) on opposite side of Guide Track Bracket to install set screw (Fig. 53).

Step 3: Align the Material Rollers

Call SSM Technical Service for instructions (763)-755-1600.

ACCESSORIES

Safety Speed offers several accessories for the vertical panel saws/routers and horizontal routers.

Tools Required for Accessory Installation

- **9/16" wrench**; Frame Stand, Quick Stop, Stop Bar, Hold Down Bar, Extension Tables
- **5/8" wrench**; Fixed Stand
- **3/4" wrench**; Frame Wheels
- **9/16" deep socket**; Fixed Stand
- **Center Punch**; Stop Bar
- **7/32" drill bit**; Stop Bar, Quick Stop
- **Drill**; Stop Bar, Quick Stop

Frame Extensions

(Only available for 7000's)

The Frame Extensions Accessory adds 20" (500mm) to each end of the tool frame. It includes two extensions and fasteners.

Extensions are recommended for cutting panels longer than 10 ft. (3040mm).

Installation:



Unplug tool before making adjustments or installing accessories.

Observe appropriate Lockout/Tagout procedures to insure the tool cannot accidentally be powered.

Attach the extensions to the back of the frame as shown in figure 54. It is not necessary to remove any parts from the machine to install the extensions.

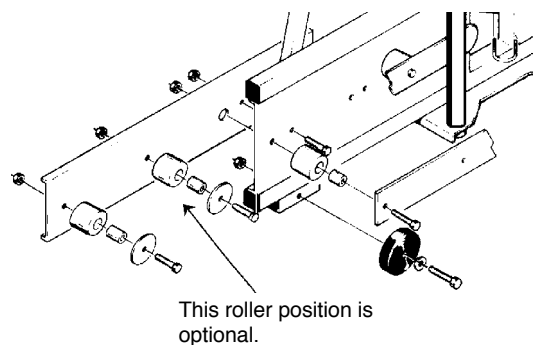

**Figure 54 Installing the Frame Extensions
(viewed from rear of frame)**

Stop Bar

The Stop Bar Accessory fits between the lower pair of horizontal frame members. It provides preset flip stops for repetitive cuts. Six or eight flip stops are included (depending on the model), and additional stops can be added.

Installation:



Before beginning installation, disconnect the power supply to the motor, raise the carriage to the top of the guides, and lock the carriage in place with the lock knob. Observe appropriate Lockout/Tagout procedures to insure the tool cannot accidentally be powered.



Be sure the tool frame is securely supported and cannot be tipped over during this installation procedure. An additional person should support and stabilize the frame at all times during the installation.

1. Position the stop bar in the bottom left side of the frame as shown in figure 55, resting against the bottom horizontal arm and the vertical back supports.

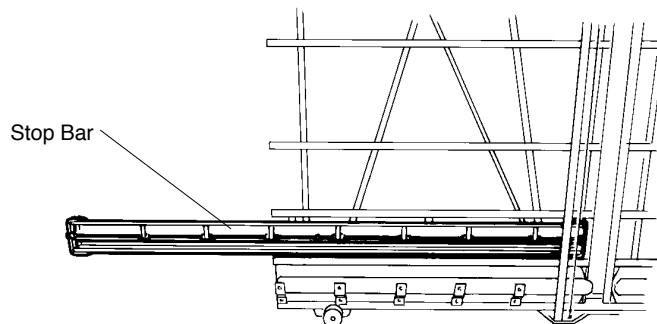
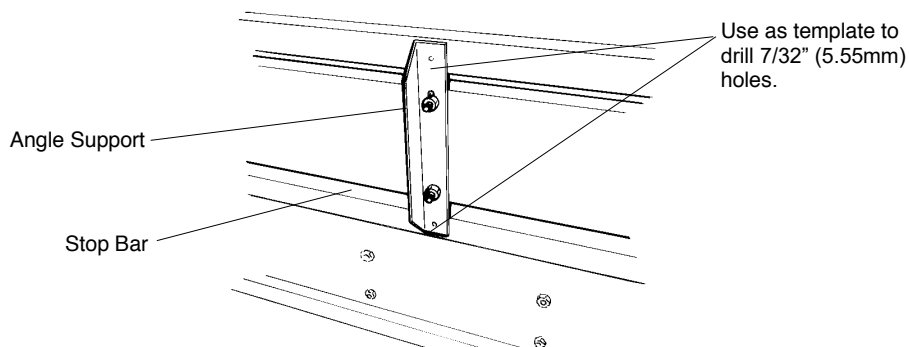

Figure 55: Installing the Stop Bar

2. Working from the front of the tool, attach the three angle supports (Fig. 56) to the back of the Stop Bar, using six 5/16 x 3/4" (7.9mm x 19.05mm) hex-head cap screws and nuts. Tighten the nuts securely.



**Figure 56: Installing the Stop Bar
(viewed from the rear)**

3. Push the stop bar housing as far toward the center of the tool as possible.
4. Working from the back of the machine, use the angle supports as templates to drill six 7/32" (5.55mm) holes (two per bracket) in the horizontal tubes of the frame.
5. Insert and tighten six self-tapping \square - 20 (6.35mm) hex-head screws to secure the angle support brackets to the frame tubes.
6. Measure out from the blade and adjust the stop bar ruler by sliding it left or right inside its aluminum extension.

Operation:

Set the individual flip stops to the positions desired for repetitive cuts: Loosen the collars with the provided Hex wrench, slide the collars to the desired position, and retighten them.

Multiple cuts can be made by flipping the stops up or down to position the work piece at the proper distance from the blade or bit. When setting multiple stops, remember to account for the material lost to the blade kerf.

Quick Stop

The Quick Stop Accessory provides an easy method of setting an exact repeatable cut length for crosscuts. It consists of an aluminum angle extrusion with movable tape measure, a large aluminum stop block with threaded lock knob, and mounting brackets and screws. The Quick Stop can be attached to any horizontal frame member, on any model saw. Standard Quick Stops are factory-drilled to mount on the left side of the frame; right-hand Quick Stops are available by special order.

Installation:



Before beginning installation, disconnect the power supply to the motor, raise the carriage to the top of the guides, and lock the carriage in place with the lock knob. Observe appropriate Lockout/Tagout procedures to insure the tool cannot accidentally be powered.



Be sure the tool frame is securely supported and cannot be tipped over during this installation procedure. An additional person should support and stabilize the frame at all times during the installation.

1. Attach the two mounting brackets to the long aluminum angle bar of the Quick Stop as shown in figure 57, using the screws provided.

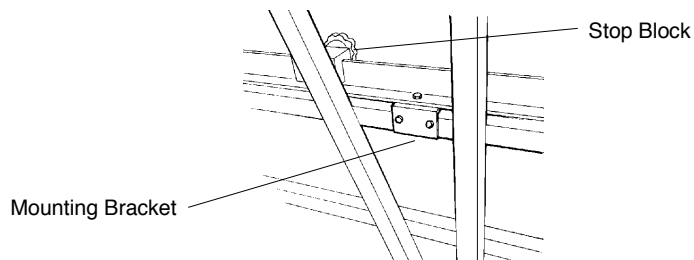

**Figure 57: Installing the Quick Stop
(viewed from rear of frame)**

2. Set the assembled angle bar on the next-to-lowest horizontal bar on the left side (as you are looking at the frame in Fig. 57 & 58). The standard ruler will be covered after installing this accessory.

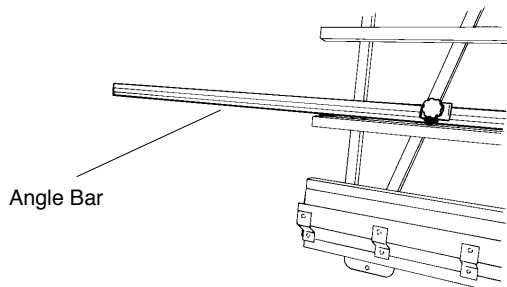

Figure 58: Installing the Quick Stop

3. Push the Quick Stop as far toward the center of the tool as possible.
4. Using the mounting bracket holes as a template, drill four 7/32" (5.55mm) holes in the tool frame.
5. Attach the brackets to the frame, using four \square -20 (6.35mm) self-tapping hex-head screws.
6. Measure from the blade and adjust the Quick Stop measuring tape by sliding it in the angle extrusion.

Operation:

1. Position the stop block at the desired cut length, as shown by the Quick Stop measuring tape, and secure the block with the lock knob (Fig. 59).
2. Raise the carriage to the top of the guides.
3. Slide the work piece behind the carriage, and hold it firmly against the stop block.



Never reach behind the carriage!

4. Cut the work piece with a smooth, continuous down stroke of the carriage.

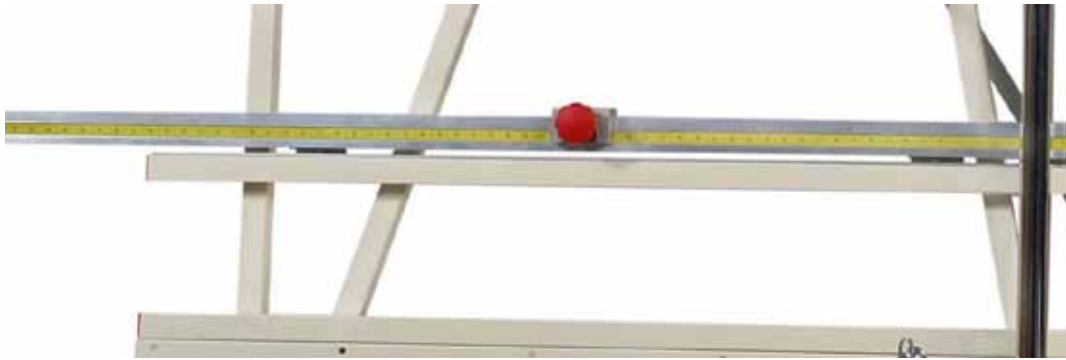

Figure 59: Quick Stop installed

Midway Fence (standard on 7400)

The Midway Fence Accessory is a removable horizontal work piece support that mounts halfway up the tool frame. It allows narrow work pieces to be worked at waist height. The fence consists of left and right fixed brackets that mount to the frame, and removable supports for each side. The accessory contains the components shown in figure 60.

Installation:



Unplug tool before making adjustments or installing accessories.

Observe appropriate Lockout/Tagout procedures to insure the tool cannot accidentally be powered.

NOTE: All hex nuts furnished with this accessory are lock nuts. During pre-assembly, DO NOT completely tighten these nuts.

1. Lay out the parts shown in figure 60 on a horizontal surface (table or bench) for pre-assembly. Note that one end of each fence extrusion is cut at a 45° angle. The units should be pre-assembled so that these beveled ends will fit against the center of the tool frame at final assembly.

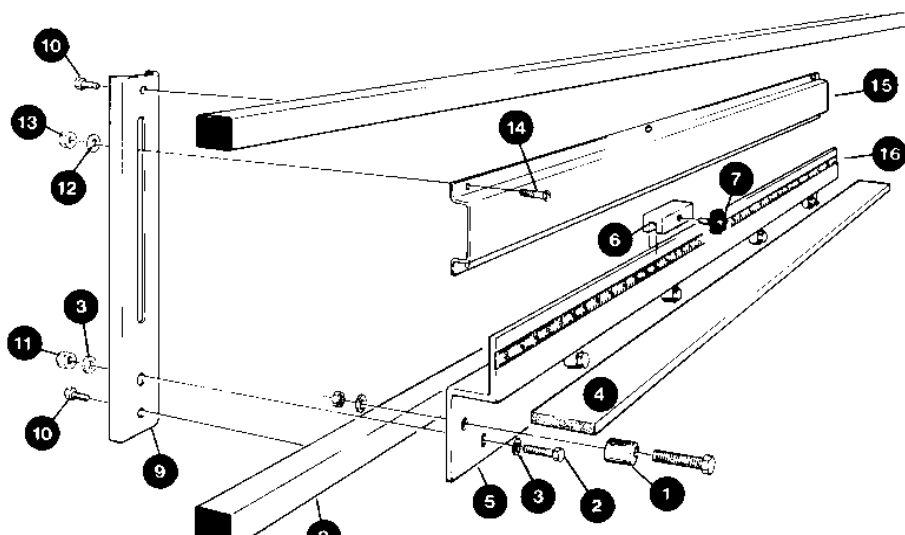

Figure 60: Pre-assembly of Midway Fence

- Set the complete right-hand fence assembly onto the tool frame as shown in figure 61.

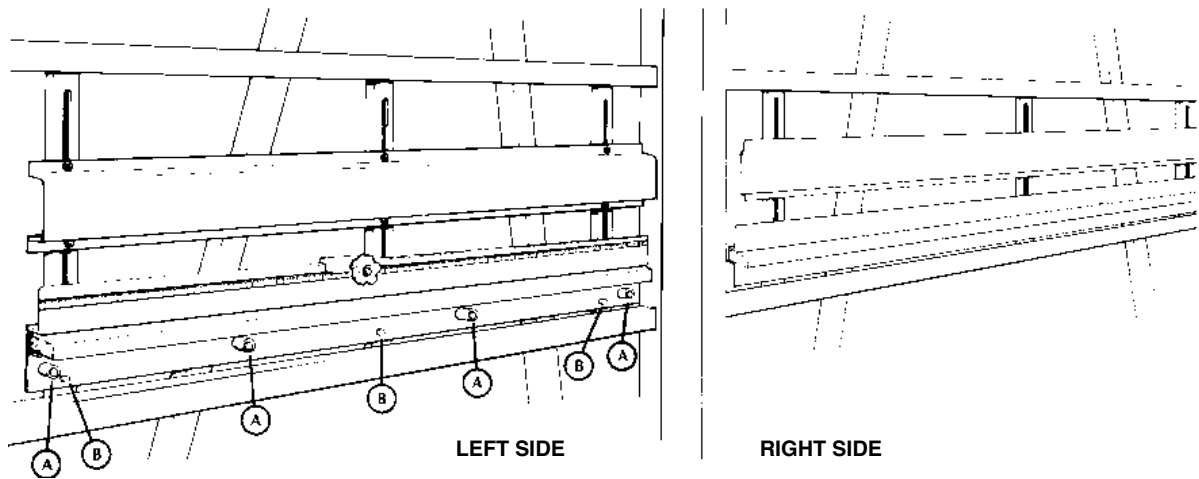

Figure 61: Mounting the Midway Fence



Fig. 62: Midway fence installed

- Tip the top of the rear support brackets (#9 in Fig. 60) under the **upper** horizontal frame member (#8), raise the fence, and push the lower ends of the rear support brackets down behind the **lower** horizontal frame member. The nuts may have to be loosened slightly to perform this step.
- Tap the entire fence system toward the center of the tool frame, and align (as closely as possible) the 45° angle of the aluminum extrusion (#5) with the 45° angle of the vertical tube at the center of the frame. To assure a neat appearance, be sure the rear support brackets (#9) are flush top and bottom with the machine frame tubes, and that they are at a 90° angle to the horizontal machine frame tubes.
- Double-check the position of the complete fence assembly. Using the holes in the rear support brackets as a template, drill six 7/32" (11.11mm) mounting holes in the machine horizontal frame tubes, and secure with six self-tapping screws.
- Repeat Steps 2 through 5 on the left-hand side of the frame.
- Mount the wooden fence sections (#4), with the 45° angle ends toward the center of the machine, between the aluminum extrusion sections and the cam-type spacers (#1). When not in use, the two wooden fence sections can be stored in the material support channels (#15) on each side.
- The friction fit of the wooden fence sections between the aluminum support bracket and the cam-type spacers can be adjusted by turning the bolt heads with a wrench. This fit can be readjusted at any time without realigning the fence system.
- Align the fence system (see Fence Alignment, next).

Fence Alignment

1. Disconnect the power supply to the tool.
2. Remove the blade guard.
3. Slightly loosen the bolts that secure the aluminum extrusion (#5, Fig. 60) to the rear support brackets (#9), to allow the extrusion to be moved up or down by tapping it with a mallet.
4. Tap the extrusion to align it evenly, 1/4" (6.35mm) above the **lower** horizontal frame member (#8).
5. Place a carpenter's square on the wood fence, with the longer side on the fence and the shorter side against the saw blade. Raise and lower the carriage to check if the saw blade maintains alignment with the edge of the square. Gently tap the **outside** edge of the fence system to bring the wooden fence and the carpenter's square into alignment with the saw blade travel.
6. Reinstall the blade guard and reconnect the power supply.
7. Using a sample panel approximately 18" (458mm) wide and 40" (1016mm) long, and a freshly sharpened saw blade, trim 1" (25mm) off the end of the panel.
8. Remove the panel from the fence. Turn it around, **keeping the same edge down**. Trim 1" (25mm) off the other end.
9. Measure the top and bottom of the piece. When the measurements are the same, or within the tolerance of the machine, tighten all securing bolts.
10. To align the left half of the fence, place a 6-ft (1830mm) or 8-ft (2440mm) straightedge on the right-hand fence. Move it to the left until it extends the full length of the left wooden fence, 48" (1220mm). Clamp the straightedge to the frame of the machine. Carefully adjust the left aluminum extrusion until the top of the wooden fence gently touches the bottom of the straightedge along its entire surface. Retighten all securing bolts.
11. To adjust the rulers, measure out from the saw blade and place a vertical pencil mark at 24" (610mm). Place both thumbs on the face of the ruler, and slide the ruler to the right or left to the proper location. Test-cut a piece of scrap material to check the ruler position.

SPECIFICATIONS

Table IV: Vertical Panel Saw/Router Specifications

Saw Model	Dimensions				Maximum Crosscut	Cut Thickness	Volts AC 3~	Horse Power*
	Length	Height	Depth	Weight				
7000	120"/3050mm	96"/2440mm	46"/1170mm	950lbs/431kg	64"/1625mm	2.00"/50mm	208-230	2.00
7000M	120"/3050mm	96"/2440mm	46"/1170mm	950lbs/431kg	64"/1625mm	2.00"/50mm	208-230	3.00
7000HD	120"/3050mm	96"/2440mm	46"/1170mm	975lbs/442kg	64"/1625mm	1.75"/45mm	208-230	2.00
7400	120"/3050mm	96"/2440mm	46"/1170mm	987lbs/447kg	64"/1625mm	2.125"/55mm	208-230	2.00
7400M	120"/3050mm	96"/2440mm	46"/1170mm	987lbs/447kg	64"/1625mm	2.125"/55mm	208-230	3.00
7400XL	156"/5118mm	96"/2440mm	46"/1170mm	1050lbs/476kg	64"/1625mm	2.125"/55mm	208-230	2.00
7400XLM	156"/5118mm	96"/2440mm	46"/1170mm	1050lbs/476kg	64"/1625mm	2.125"/55mm	208-230	3.00

*All models available with optional; 2 HP, 1~ 208-230V, 50/60 Hertz; or 3 HP, 3~ 440-460V, 50/60 Hertz

ACCESSORIES

Description:

Part #

MEASURE WITH ACCURACY

DIGITAL QUICK STOP

H6460-DRO

7000, 7000M, 7000HD

DIGITAL READ OUT

H6460-DRO-U

7400, 7400M, 7400XL, 7400XLM

LASER LINE

LL-7400

STOP BAR

H6450

MIDWAY FENCE FLIP STOP

6480

SAWGEAR AUTO LENGTH STOP

SG08-PS

(with "HOOP" saw frame)

SAWGEAR AUTO LENGTH STOP

SG08-DM

(standard saws)

TIGERSTOP AUTO LENGTH STOP

TS08-PS

(with "HOOP" saw frame)

Description:

Part #

MAXIMIZE DUST COLLECTION

INDUSTRIAL VACUUMS

1 HP, 100 CFM, 90" S.P.

740C

2.25 HP, 115 CFM, 110" S.P.

740CC

EXPAND CAPABILITY

MIDWAY FENCE

7000, 7000M, 7000HD

H6470

FRAME EXTENSIONS

7000, 7000M, 7000HD

6430

CHIP FREE

SCORING

7400, 7400M, 7400XL, 7400XLM

740090

PANEL MOVER

PANEL DOLLY

PD1

NOTE: Saw Blades listed on page 35



Abbeon Cal, Inc.,
1363 Donlon Street Unit 1, Ventura, CA 93003-8387
800-922-0977 www.Abbeon.com
E-mail: abbeoncal@abbeon.com