

FORSTHOFF



QUICK-S-ELECTRONIC

DE Bedienungsanleitung
EN Operating Instructions
FR Instructions d'emploi
ES Instrucciones de manejo
PT Instruções de Operação
IT Istruzioni d'uso
NL Bedieningsinstructies
DA Betjeningsvejledning

SV Driftinstruktion
NO Bruksanvisning
FI Käyttöohje
EL Οδηγίες χειρισμού
TR Kullanma Talimatı
PL Instrukcja obsługi
HU Kezelési utasítás
CS Návod k obsluze

SK Návod na obsluhu
RO Instrucțiuni de utilizare
SL Navodila za uporabo
BG Упътване за обслужване
ET Kasutusjuhend
LT Vartotojo žinynas
LV Lietošanas instrukcija
RU Инструкция по эксплуатации

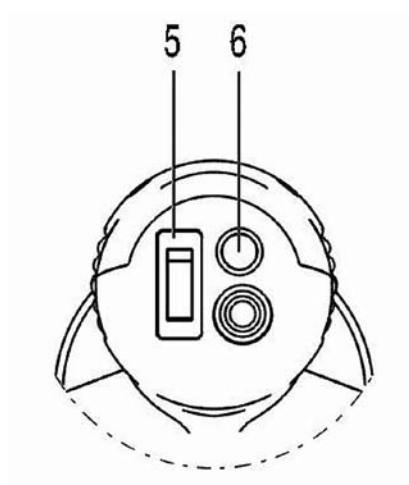
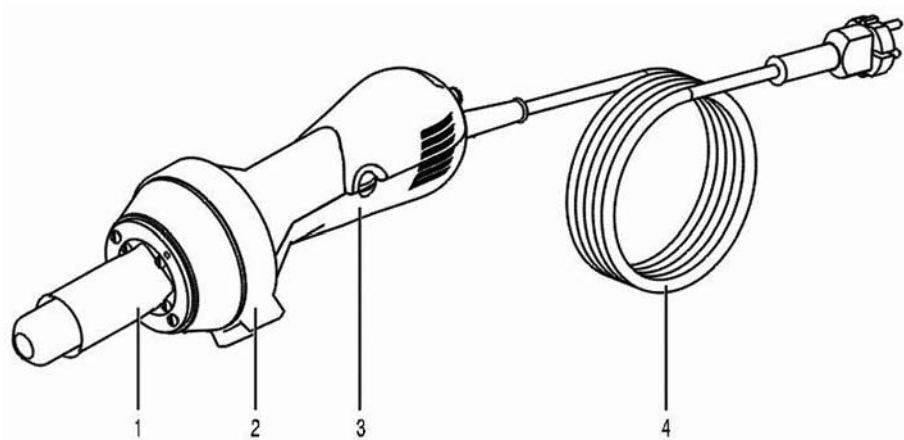





General Safety Information

CAUTION! Read all the instructions. Errors in observing the following instructions can result in electrical shock, fire and/or serious injuries. The term “electrical tools” used below, refers to mains-operated electrical tools (with a mains cable) and to battery-operated electrical tools (without a mains cable).

KEEP THESE INSTRUCTIONS IN A SAFE PLACE.

Explanations for utilized symbols

	Observe operating manual
	Danger of explosion
	Danger of fire
	Hot surface

The device

- has been designed and tested in accordance with EN 60335-1 in connection with EN 60332-2-45.
- is CE certificated
- has left the plant in perfect condition as far as safety is concerned.

In order to maintain this state, it is necessary to observe the contents of this safety information when handling the device (transportation, storage, installation, commissioning, operation, servicing, de-commissioning) as well as the rating plates, labelling and safety information attached to the device, otherwise it could endanger persons and damage the device itself as well as other equipment.

This safety information applies in the Federal Republic of Germany. The relevant national rules and regulations must be observed when it is used in other states/countries. The generally valid safety and accident prevention regulations must be observed in addition to the references in this Manual.

If the information in this safety information does not suffice, then you can contact the manufacturer at any time at the indicated address.

Please check the packaging and file a complaint

with the forwarding agent immediately in the case of any damages.

Please examine the device prior to commissioning to ensure that the device has no damages of any kind. In the event of doubt, please ask a qualified electrician for advice or contact the address shown below.

 If you assume that a danger-free operation is no longer possible, then take the device out of operation and secure it from being restarted unintentionally.

One must assume that a danger-free operation is no longer possible

- if the device or the connection lead shows visible damages,
- if the device no longer functions,
- if it was stored under detrimental conditions,
- after severe demands due to transportation.

Workplace

Keep your working area clean and tidy. Disorderly and non-illuminated working areas can result in accidents.

Keep children and other people away from the electrical tools while in use. You can lose control of the device if you are distracted.

Use the device only for its intended use (see below).

 Do not reach into the flow of hot air. Touching the jet or the protective pipe can result in burns when it is hot.

 A fire can develop if the unit is not handled carefully.

Caution when using the device near flammable materials. Do not direct towards one and the same point for an extended period of time.

Heat can be conveyed to flammable materials, which are covered.

 Never work with the device in surroundings that could be explosive, or in which flammable liquids, gases or dust can be found. Electrical tools generate sparks, which can ignite the dust or the fumes.

 The connection lead may not come into contact with hot parts.

Place on the stand and allow to cool off after use, before it is packed away.

Toxic fumes can develop when processing lacquers/paints and plastics. Avoid inhaling the fumes. Ensure the working area is well ventilated.

Do not leave the device unsupervised, as long as it is in operation.

Electrical safety

Before commissioning, please check whether the operating voltage for the device and the line voltage match.

If the device is brought into warm surroundings from cold surroundings, condensation may form on it. In that case, wait until temperature adjustment has occurred. There is a risk of mortal danger if the device is commissioned when it is covered in condensation!

The connection plug on the device must fit into the socket. The plug must not be changed in any way. Do not use any adapter plugs together with any protective grounded devices. Unmodified plugs and suitable outlets reduce the risk of an electric shock.

Avoid body contact with grounded surfaces such as those on pipes, radiators, stoves and refrigerators. There is an increased risk due to electric shock if your body is grounded.

Keep the device away from rain or moisture. The penetration of water into an electrical device increases the risk of an electric shock.

Do not use the cable for other purposes such as carrying or hanging up the device, or to pull the plug out of the electrical outlet. Keep the cable away from heat, oil, sharp edges or moving devices. Damaged or tangled up cables increase the risk of an electric shock.

If you work outdoor with an electrical tool, always use special extension cables that are approved for external areas. Using suitable extensions cables for outdoor areas reduces the risk of an electrical shock.

Personal safety

This device is not intended to be used by persons (including children) with limited physical, sensory or mental capabilities or persons who have insufficient knowledge and/or experience, unless they are being supervised by a person responsible for their safety or have received instructions on how to use the device from that person. Electrical tools are dangerous if they are

used by inexperienced persons.

Always store electrical tools out of the reach of children when not in use.

Please be cautious and pay attention to what you are doing and use common sense when working with an electrical tool. Do not use the device if you are tired or under the influence of drugs, alcohol or medications. Not paying attention for just a moment can result in serious injuries when using such a device.

Avoid unintended commissioning. Always make sure that the switch is in the "OFF" position before you insert the plug in the socket. If you have the finger on the switch when you are carrying it or have it switched on when you connect it to the power supply, this can result in accidents.

Do not overestimate yourself! Ensure you are standing securely and always maintain your equilibrium (balance). That way, you are in a better position to control the device in the event of an unexpected situation.

Wear suitable clothing! Do not wear any overly large clothing or jewellery. Keep hair, clothing and gloves away from any moving parts. Loose clothing, jewellery or long hair can be caught in moving parts.

Careful Handling and Use of Electrical Tools

Do not overload the device. Use the correct electrical tool that is intended for the task at hand. You can work better and more securely in the indicated performance range with the correct electrical tool.

Never use an electrical tool that has a faulty switch. An electrical tool that cannot be switched on or off any more is dangerous and must be repaired.

Pull the plug out of the socket before you adjust the device settings, change accessories or put the device away. These precautions prevent the device from starting unintentionally.

Treat the device with care. Examine it to see whether the moving device parts function perfectly and do not stick or to see whether any parts are broken or damaged to such an extent that the functionality of the device is impaired. Have damaged parts repaired before using the device. Many accidents are caused by poorly maintained electrical tools.

Utilise electrical tools, accessories, add-on tools,

etc in accordance with these instructions and in the manner that is prescribed for this special device type. Take the working conditions and the activity that is to be performed into consideration while doing this. The use of electrical tools for other applications than those that are intended can result in dangerous situations

Prior to cleaning: Switch off mains! Use a mild cleaning agent and a damp cloth for cleaning. Never clean devices so they are dripping wet!

Service

Never have your device repaired by anyone but qualified personnel and always use original spare parts. This will ensure that the safety of the device is maintained.

Only authorized personnel should exchange fuses or perform repairs. Please contact the address shown below.

Intended Use

This hot air device is intended for all the hot air applications listed in this operating manual; always observe the safety regulations and only use original accessories with it.

Applications A:

- Welding of thermoplastics and elastomere bitumen
- Shrinking of heat-shrinkable tubing, foil packaging
- Warming up thermoplastic semi-finished goods for purpose of forming
- Drying of watery wet surfaces
- Unthawing of frozen water pipes
- Removing old shellac varnish, synthetic enamel
- Activating and dissolving adhesives and hot-melt type adhesives which do not contain any solvents

Applications B:

- Industrial assembly work
- Drying and heating up processes of all kinds
- Activating and dissolving adhesives and hot-melt type adhesives which do not contain any solvents
- Heat-shrinking and welding of foil packaging and preforms
- Separating and fusing together synthetic threads and textiles

- Sterilizing packaging materials
- Removing plastic flashing and finish-polishing plastic surfaces

The device is not suitable to be used in an explosive atmosphere!

Touching hot jets or reflectors can lead to serious burns. Before assembling or changing jets or reflectors, allow the device to cool down completely or use suitable tools. The jets and reflectors must be mounted firmly and safely onto the device.

Hot jets and reflectors can ignite items or the base of the device. Always ensure you only set down hot jets and reflectors on a fire-resistant base.

Incorrect or damaged jets can cause a blockage of hot air and damage the device. Use only original jets or reflectors!

Device elements:

1. Heating element pipe
2. Rubber stand
3. Handle
4. Mains connection lead
5. Mains outlet
6. Potentiometer for setting temperature

Mounting and firm installation:

Mounting and firm installation:

The device is intended for installation in machinery and equipment and is designed for continuous operation.

Please ensure the following points when installing:

- that only cold air is supplied
- that no heat blockage can develop
- that the device is protected against mechanical vibrations and jarring
- that other sources of hot air do not blow on the device

Commissioning:

Check mains connection lead and plug for mechanical damages!

Observe the mains voltage! The mains voltage must coincide with the details on the rating plate.

Activation:

Set the mains switch 5 to position 1. Adjust the temperature using the potentiometer 6, if necessary. The warm-up time for the device is approx 5 minutes.

De-activation:

Turn the potentiometer 6 to position 0 for cooling down. Once the unit has cooled down, set the switch 5 to 0.

Maintenance, service and repairs:

Check mains connection lead and plug for breaks and mechanical damages!

Before commencing with any work on the device, disconnect the mains plug!

Always keep the device and air intake screens clean. If necessary, clean the dirty screens with a brush while the device is switched off. Only original accessories may be used.

Once the carbon brushes reach the minimum length, the fan motor will switch off automatically. The service life of the carbon is at least 1500 hours (approx). Have the carbon brushes replaced by an authorised service centre or a specialist company.

Repairs on the device should only be performed by an authorized repair shop.

Technical Data:

Nominal voltage range:	120 V or 230 V~
Frequency range:	50Hz - 60Hz
Output:	120V 1650W or 230V 1500W
Output temperature:	≤ 700°C
Noise emission level:	< 70dB
Protection class:	II /  (double insulated)
Weight:	1.4 kg including mains connection lead

Disposal

Do not dispose of in the household trash. Add the device that is no longer able to be used to a separate collection for the purpose of environmentally friendly recycling.

Help in the event of problems:**Forsthoff GmbH**

Freiheitstr. 24
42719 Solingen
DEUTSCHLAND
Tel: +49 (0)212 - 33 60 52
Fax: +49 (0)212 - 33 69 16
E-Mail: info@forsthoffwelding.com
Internet: http://www.forsthoffwelding.com

**EU Declaration of Conformity
Forsthoff GmbH, Freiheitstr. 24,
42719 Solingen**

hereby declares that the product
Equipment type: Hot air fan
Model name: QUICK-S-ELECTRONIC

agrees with the requirements of the following European Directives:

EU Directive 2006/95/EU - NSR
EU Directive 2004/108/EU - EMC

The concurrence of the specified product with the requirements of Directive 2006/95/EU is proven by the observance of the following standards:

EN 60335-1:2002 + A11:2004 + A1:2004 + A12:2006 + Corrigendum:2006 + A2:2006
EN 60335-2-45:2002

the last two digits of the year in which the CE marking was attached: 08

The concurrence of the specified product with the requirements of Directive 2004/108/EU is proven by the observance of the following standards:

EN 55014-1:2006
EN 61000-3-2:2006
EN 61000-3-3:1995 + A1:2001 + A2:2005

This Declaration certifies the compliance with the aforementioned Directives, but does not encompass any assurances with regard to properties in a legal sense. The Safety Information in the supplied product documentation must be observed.

Solingen, 28.11.2008

Andrea Forsthoff-Neeff
Managing Director, Owner

Warranty

A warranty is provided for this device for a period of one year from the date of purchase (to be proven by invoice or delivery note). Damages that have occurred will be rectified by a replacement delivery or a repair. Heating elements are excluded from this warranty.

Other entitlements are excluded, with exception of the legal provisions.

Damages, which are attributed to natural wear, overloading or improper use will be excluded from the warranty.

There are no entitlements for devices, which have been modified or changed by the purchaser.

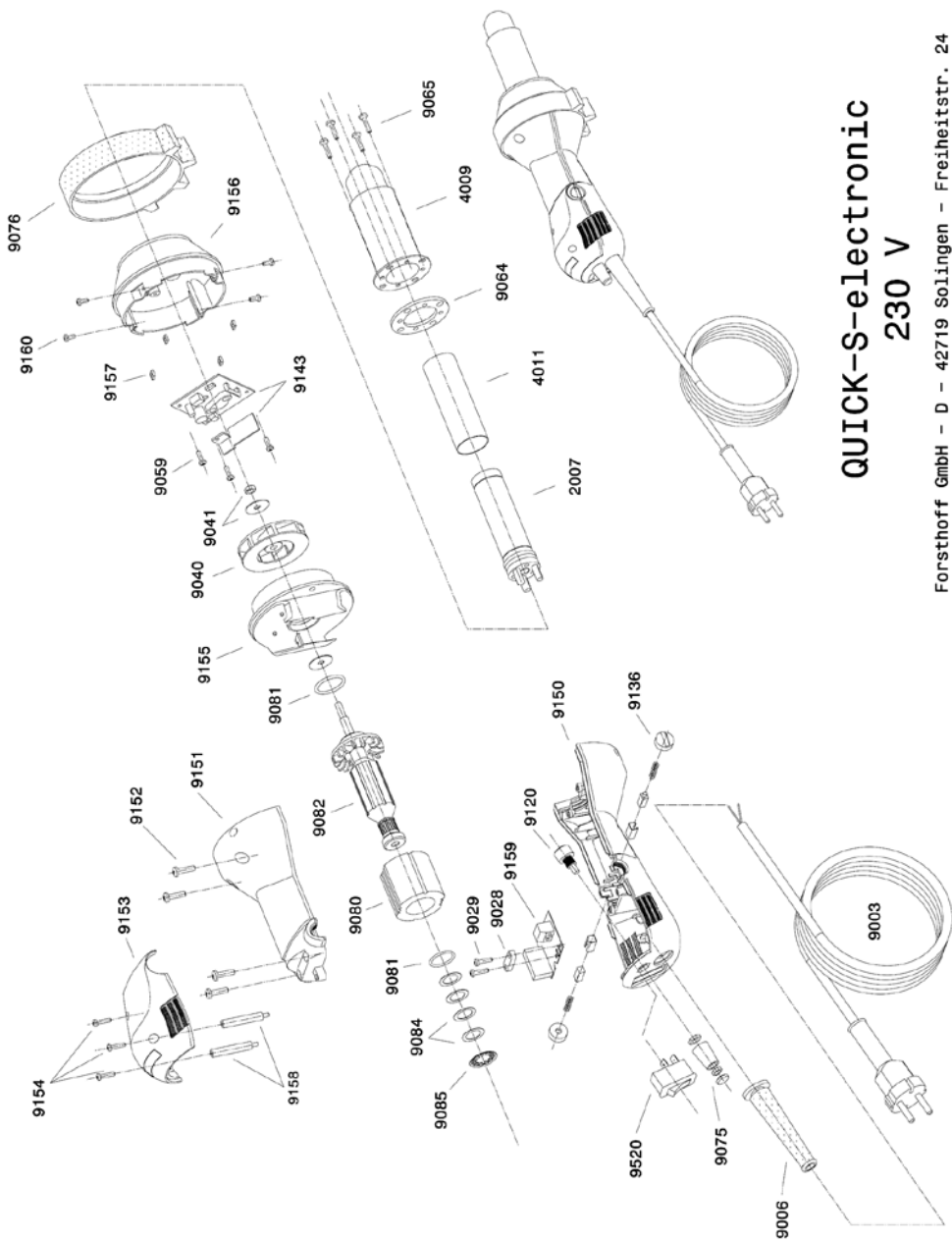

QUICK-S-electronic 230 V

Forsthoff GmbH - D - 42719 Solingen - Freiheitstr. 24
 Telefon +49 (0) 212 / 33 60 52 Telefax +49 (0) 212 33 69 16
 E-mail: info@forsthoffwelding.com

Technische Änderungen vorbehalten

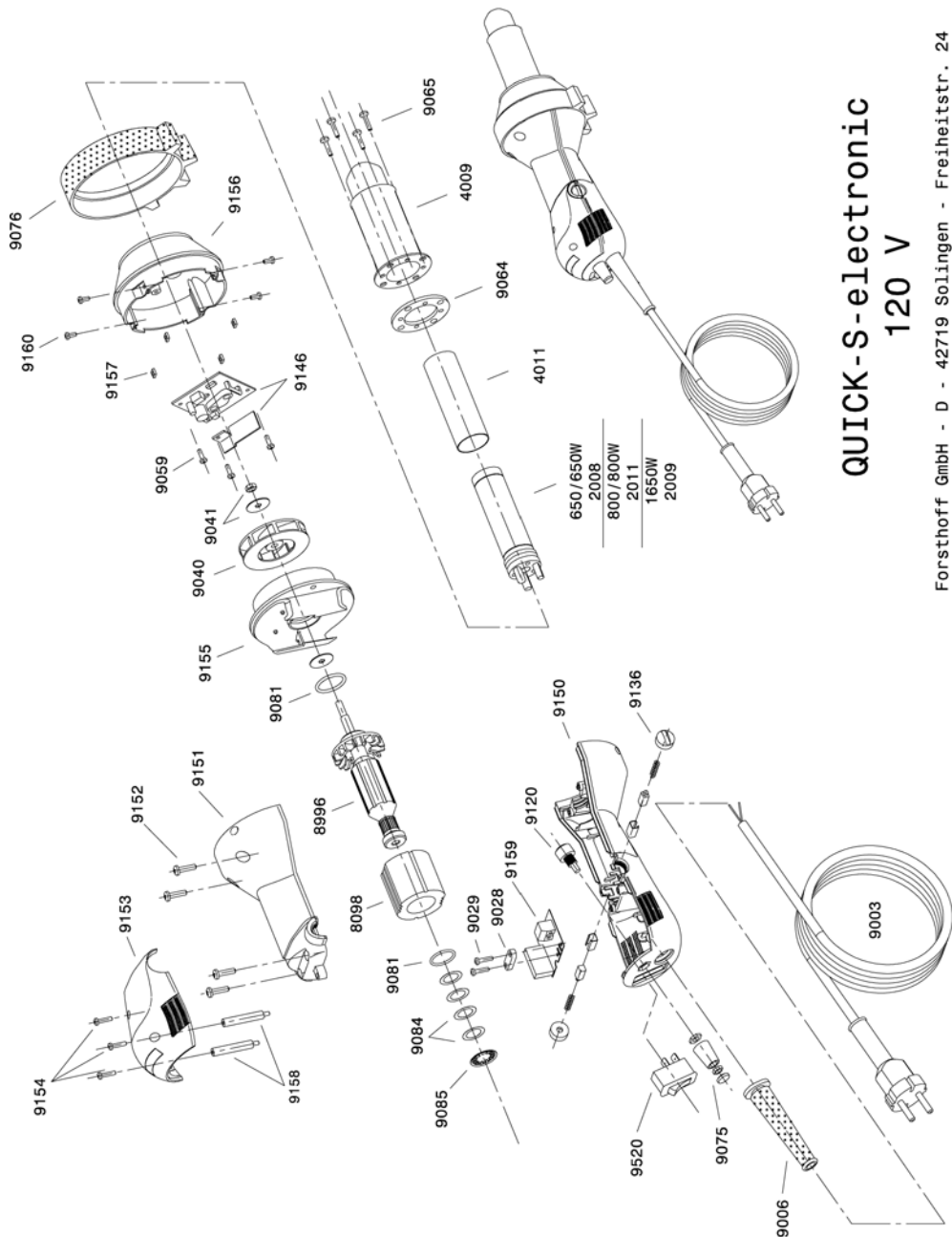

QUICK-S-electronic 120 V

Forsthoff GmbH - D - 42719 Solingen - Freiheitstr. 24
 Telefon +49 (0) 212 / 33 60 52 Telefax +49 (0) 212 33 69 16
 E-mail: info@forsthoffwelding.com

Technische Änderungen vorbehalten