

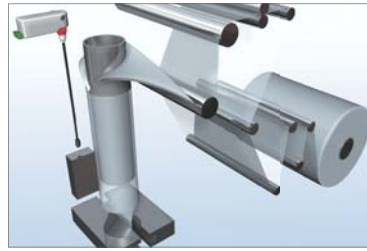

Applications



Pillow Packing (joint nozzle + shower tube)



Vibratory bowl feeder (joint nozzle + shower tube)

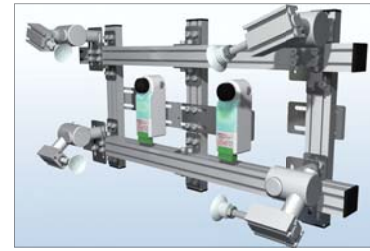

Robots for molded parts

External dimensions

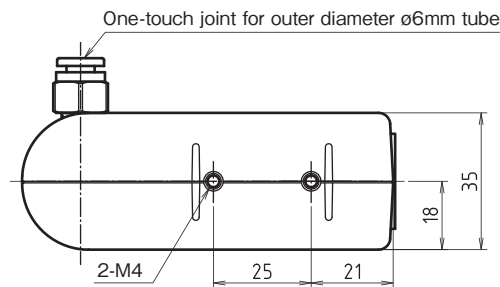
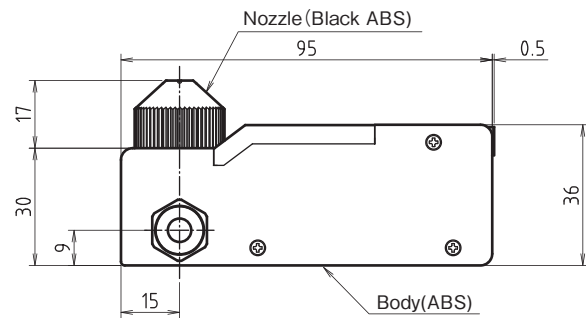
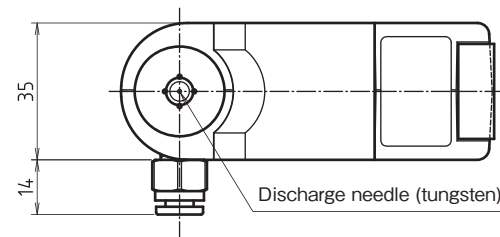

Enclosed power harness

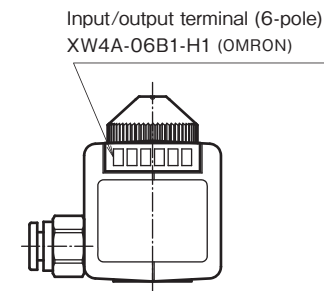
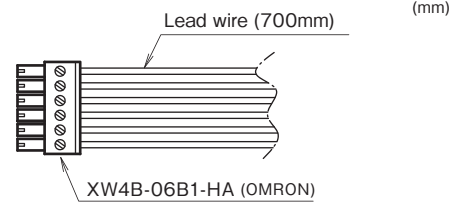

Specifications

Input power	24VDC ±5% ripple (p-p) 10% max
Current consumption	90mA max.
Discharge Voltage	AC5.6kVp-p
Ionizing method	AC Corona discharge method (37kHz)
Ion balance	±10V or less (at the time of factory shipment)
Decay time	0.7 sec or less (±1000V → ±100V) (at the time of factory shipment)
Safety functions	Stops in case that high voltage error occurs (short-circuit) Current fuse 0.5A/600V
Operating air pressure	0.1MPa~0.6MPa
Air Consumption	210L/min (0.3MPa)
Air Inlet Joint	ø6mm one-touch joint
Operation Display	Operation: Green LED Abnormal stop: Red LED
Connectors	6-pole type OMRON XW4A-06B1-H1
Ozone production rate	0.05 ppm or less
Operating environment temperature and humidity	5~40°C 35~65%
Storage environment temperature and humidity	0~60°C 35~85%
CE	EC directive (EMC) compliant
Installation	Indoor only
Material	Body/Nozzle: Fire-retardant ABS resin Needle electrode: Tungsten
Dimensions	L95×W50×H47mm
Weight	104g

● Air Consumption (w/ standard nozzle)

Input Pressure (MPa)	0.1	0.2	0.3	0.4	0.5	0.6
Air Consumption (L/min)	86	150	210	260	315	375

Options

Flared Nozzle	N-2FN	EDP No. 806086
Tube-fitting Nozzle	N-2TN	EDP No. 806085
Silent Nozzle	N-2WN	EDP No. 806087
Straight Silent Nozzle	BB-ZSN	EDP No. 621708
Electrode Needle Replacement Screwdriver	G-7DR	EDP No. 806061
Shower Tube	N-2C6B	EDP No. 621706

● Replacement parts : Electrode Needle GN-H EDP No. 806124

WARNING

- For safety purposes, read the instruction manual carefully before using the unit.
- Do not use this product in an explosion-proof area.
- A high voltage is applied on this product. Make sure that water, oil, solvents, etc., do not come in contact.
- Avoid dew condensation as it can result in electric shock or product damage.
- Keep away metal objects such as tools or needles, or body parts such as fingers, hands or face from the needle electrode because a high voltage is applied on the needle electrode.

VESSEL CO., INC

17-25, Fukae-kita 2-chome, higashinari-ku, Osaka 537-0001 JAPAN
Tel : +81(0)6 6976 7778 Fax : +81(0)6 6972 9441

VESSEL EUROPE

6, avenue du 1er Mai, ZAE Les Glaises, 91120 Palaiseau FRANCE
Tel : +33(0)1 69 19 17 42 Fax : +33(0)1 69 19 42 20
E-mail : export@vessel.co.jp URL : <http://www.vessel.co.jp/english/>

Printed in Japan

● For improvements, the product specifications, size, price and other information may be subject to change without prior notice.

Distributed by

14000000.00

Compact and Precision Ionizer w/Wire-Wound Transformer

Solution for narrow and limited space like robotic arms and packing equipment



NEW

STAT·CLEAN

Pinpoint Nozzle

N-3

EDP No. 621654

Stable Ionizing Performance

Solution especially for narrow installation space in robotic arms or packaging equipment!

NOZZLE TYPE

Compact & Lightweight Air Nozzle Type

- Incorporated compactly the high-voltage power into the body case.
- Static electricity and dust are removed with powerful compressed air.
- N₂ (nitrogen gas) can be used instead of clean air.
- The N-3 unit has screw holes for mounting, allowing easy installation onto workpieces, etc.

STABILITY

AC Corona Discharge Method

NEW

- This method makes less frequent ion balance disruption caused by needle contamination.
- The high-voltage wired transformer ensures ample ionizing by stable current supply to the discharge needles.
- **Easy to clean electrode needle**
 - Remove the nozzle cap and clean the electrode needle with a cotton stick.



SAFETY

NEW

Safe Design

- The N-3 automatically stops when a high-voltage error occurs.
- **Lamp indicators clearly show the operation state.**
 - The top cover lights up in green during operation.
 - If operation stops because of a high-voltage error, the body lights up in red so the operation state can be visually checked.
- RoHS/CE compliant product.



INPUT / OUTPUT

NEW

Connector Terminal

- **Enable to connect multiple units of N-3 from the connector with a single power supply.**
 - Up to 11 units can be connected.
- **High-voltage alarm output function**
 - A signal is output to indicate that the operation has stopped due to a high-voltage error (open collector).

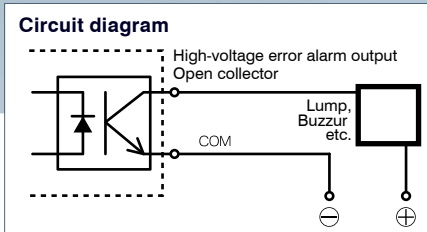

FLEXIBILITY

Nozzle variations

- Latest designed nozzles to widen the applications
- In addition to the enclosed standard nozzle, options such as Flare Nozzle and Tube-fitting Nozzle are available. Select a nozzle that matches your application.



Flared Nozzle

Tube-fitting Nozzle

Performance

Measurement conditions

1. The decay time and ion balance are measured 150mm from the front.
2. The decay time and ion balance are the values recorded at least one minute after the discharge starts.
3. The noise is measured 1m from the front of the blowoff port.
(Note that the measuring instruments sound receiving section is not directly contacted to the blowoff wind.)
4. The following values are taken in a temperature $25 \pm 2^\circ\text{C}$ and humidity $50 \pm 5\%$ measuring environment. The values may change depending on the environmental conditions.

Standard Nozzle



Air pressure (MPa)	0.1	0.2	0.3	0.4	0.5	0.6
Air flow(L/min)	70	120	170	220	270	320
Decay time	+1000V→+100V (sec.)	1.1	0.7	0.5	0.5	0.4
	-1000V→-100V (sec.)	1.0	0.6	0.5	0.5	0.4
Ion balance (V)	-6	3	2	1	4	1
Noise level (dBA)	80.8	87.3	99.4	104.1	106.2	107.1

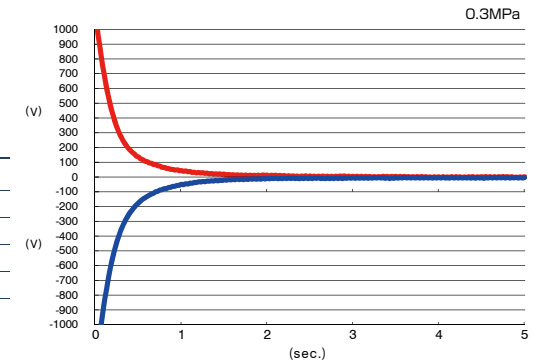

Flared Nozzle



Air pressure (MPa)	0.1	0.2	0.3	0.4	0.5	0.6
Air flow(L/min)	70	120	170	220	270	320
Decay time	+1000V→+100V (sec.)	1.4	0.7	0.5	0.4	0.4
	-1000V→-100V (sec.)	1.3	0.7	0.5	0.4	0.4
Ion balance (V)	-2	2	1	3	-1	-1
Noise level (dBA)	81.3	91.5	95.2	98.3	102.2	102.6

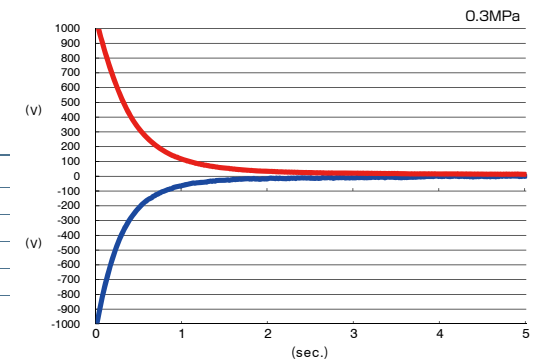

Tube-fitting nozzle + Tube 300mm



Air pressure (MPa)	0.1	0.2	0.3	0.4	0.5	0.6
Air flow(L/min)	53	90	131	172	214	252
Decay time	+1000V→+100V (sec.)	3.3	1.8	1.4	1.3	1.4
	-1000V→-100V (sec.)	3.4	1.8	1.4	1.4	1.5
Ion balance (V)	5	4	-1	-6	-8	-7
Noise level (dBA)	76.2	81.2	86.4	90.1	94.3	97.8

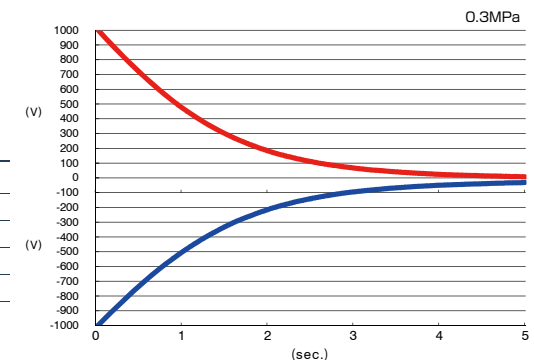

Standard Nozzle (using nitrogen gas)



Air pressure (MPa)	0.1	0.2	0.3	0.4	0.5	0.6
Air flow(L/min)	56	96	140	176	218	266
Decay time	+1000V→+100V (sec.)	2.6	3.0	2.9	2.9	2.6
	-1000V→-100V (sec.)	2.3	2.7	2.7	2.4	2.2
Ion balance (V)	-3	-8	3	-2	-1	4
Noise level (dBA)	-	-	-	-	-	-

※The above values are typical values measured with a sample unit, and do not guarantee the product performance.